

# ICOM

## INSTRUCTION MANUAL

VHF/UHF  
DUAL BAND FM TRANSCEIVER

# IC-901A IC-901E

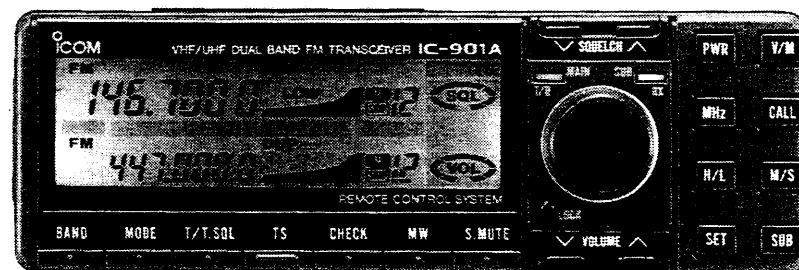

Icom Inc.

---

## FOREWORD

---

Thank you for choosing this Icom product.

The IC-901A/E is a 144 and 430 (440) MHz dual band mobile transceiver. Up to 6 band units including the SSB/CW unit and receiver unit can be connected and used with the IC-901A/E, systematically upgrading the degree of transceiver versatility with every new band unit added.

---

## IMPORTANT

---

- (1) **READ THIS INSTRUCTION MANUAL CAREFULLY** before attempting operation. If you have any questions regarding the operation of the IC-901A/E, feel free to contact your nearest authorized Icom Dealer or Service Center.
- (2) **SAVE THIS INSTRUCTION MANUAL** — This instruction manual contains important safety and operating instructions for the IC-901A/E.

---

## CAUTIONS

---

- (1) **NEVER** connect the transceiver to an AC outlet. This will ruin the transceiver.
- (2) **NEVER** connect more than 15 V DC power supplies or batteries to the transceiver. Check the source before connecting the power cable.
- (3) **NEVER** place the transceiver where normal operation of the vehicle may be hindered or where it could cause bodily injury.
- (4) **NEVER** allow children to touch the transceiver.
- (5) **DO NOT** install the transceiver where hot or cold air blows directly on it.
- (6) **DO NOT** use or place the transceiver in areas with temperatures below  $-10^{\circ}\text{C}$  ( $+14^{\circ}\text{F}$ ) or over  $+60^{\circ}\text{C}$  ( $+140^{\circ}\text{F}$ ) and in direct sunlight, such as on the dashboard.
- (7) **BE CAREFUL!** The heatsink may become hot when operating the transceiver continuously for long periods.

---

# TABLE OF CONTENTS

---

FOREWORD.....	i	10. OPERATING FM MODE .....	32 ~ 34
IMPORTANT .....	i	11. OPERATING SSB/CW MODE (OPTIONAL) .....	35 ~ 38
CAUTIONS.....	i	12. OPERATING RECEIVER MODE (OPTIONAL) .....	39 ~ 40
TABLE OF CONTENTS.....	ii	13. USING MEMORY CHANNELS ....	41 ~ 43
1. UNPACKING .....	1 ~ 2	14. OPERATING SCANS.....	44 ~ 48
2. SYSTEM OUTLINE.....	3 ~ 4	15. SPECIAL FUNCTIONS.....	49 ~ 51
3. PANEL DESCRIPTION.....	5 ~ 11	16. USING SET MODE.....	52 ~ 54
4. BASIC INSTALLATION.....	12 ~ 14	17. SELECTIVE CALLING (OPTIONAL) .....	55 ~ 62
5. SYSTEM INSTALLATION .....	15 ~ 18	18. IN CASE OF DIFFICULTY.....	63 ~ 65
6. REAR PANEL CONNECTIONS.....	19 ~ 21	19. SPECIFICATIONS .....	66
7. SYSTEM INTERCONNECTIONS ...	22 ~ 25	20. OPTIONS .....	67 ~ 68
8. PRE-OPERATION .....	26 ~ 30		
9. OPERATING DUAL WATCH.....	31		

# 1

## UNPACKING

### Power cable connections

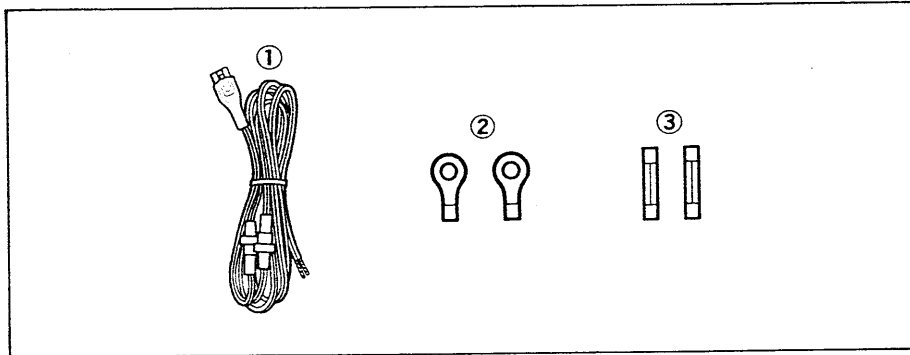

NO.	ITEM	DESCRIPTION
①	DC power cable	For applying DC power to the transceiver.
②	Battery terminals	Use terminals when connecting the DC power cable to a car battery.
③	Fuses (20 A)	Spare fuses for the DC power cable.

### Transceiver mounting

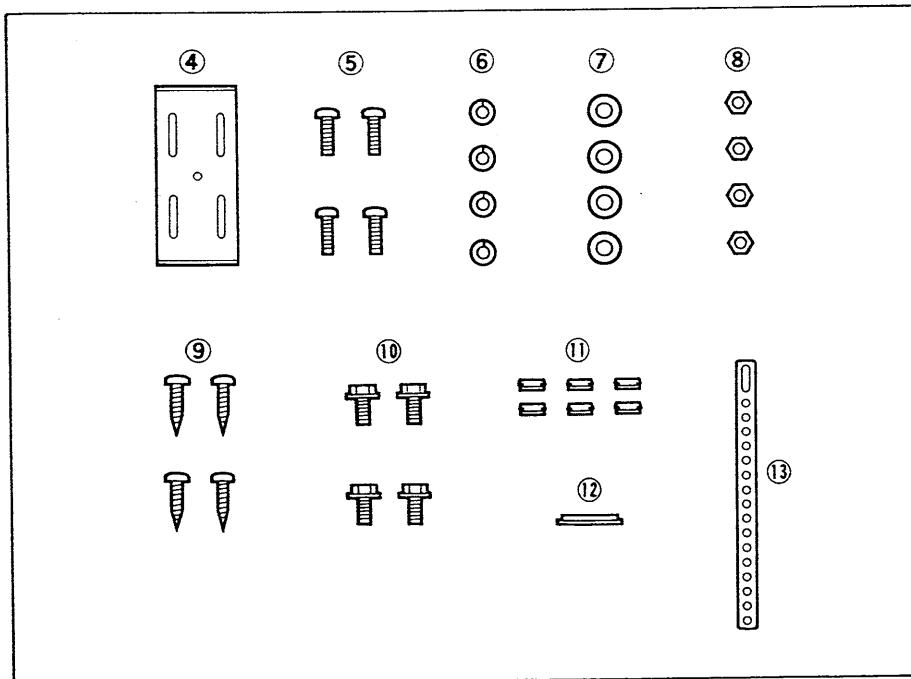

NO.	ITEM	DESCRIPTION
④	Mounting bracket	For mounting the transceiver.
⑤	Screws	
⑥	Spring washers	For installing the mounting bracket.
⑦	Flat washers	
⑧	Nuts	
⑨	Mounting screws	For mounting the transceiver.
⑩	Mounting bolts	For mounting the transceiver to the to the mounting bracket.
⑪	Rubber bushing (S)	Used to cover holes on the band unit top cover.
⑫	Rubber bushing (L)	
⑬	Mounting support bracket	For installing the transceiver.

## Remote controller installation

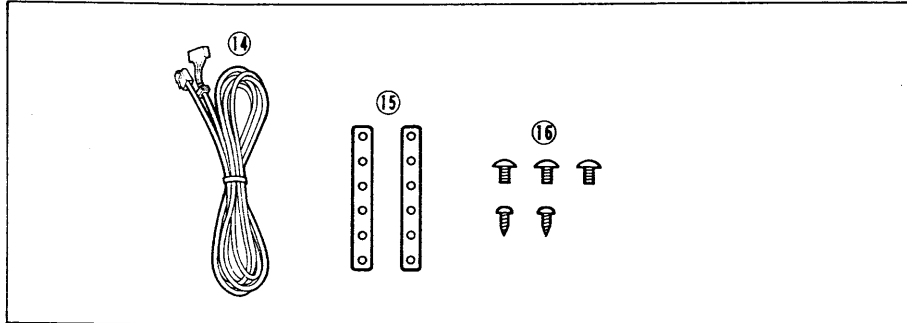

NO.	ITEM	DESCRIPTION
⑭	Remote control cable	Used when separating the remote controller and main body.
⑮	Remote controller support brackets	Used when mounting the remote controller to a vehicle dashboard, etc.
⑯	Screws	Used for attaching the brackets in item ⑮ above.

## Microphone

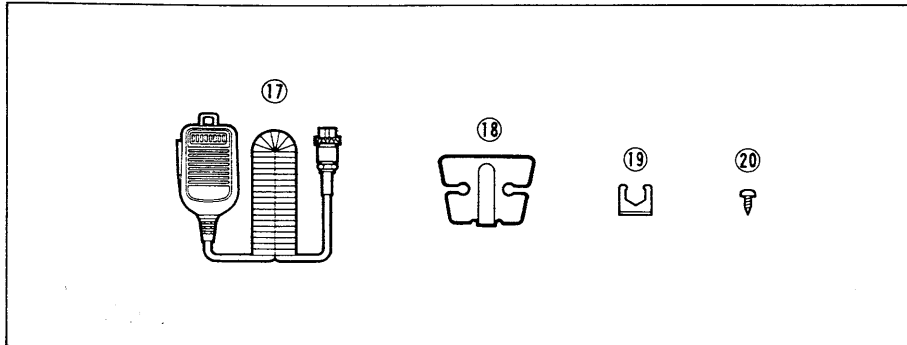

NO.	ITEM	DESCRIPTION
⑰	Microphone	U.S.A. version : HM-14 Australia version : HM-12 Europe version : HM-15
⑱	Microphone hanger	
⑲	Mic connector holder	Used for holding the mic connector.
⑳	Screw	Used for attaching the mic connector holder in item ⑲ above.

## Speaker

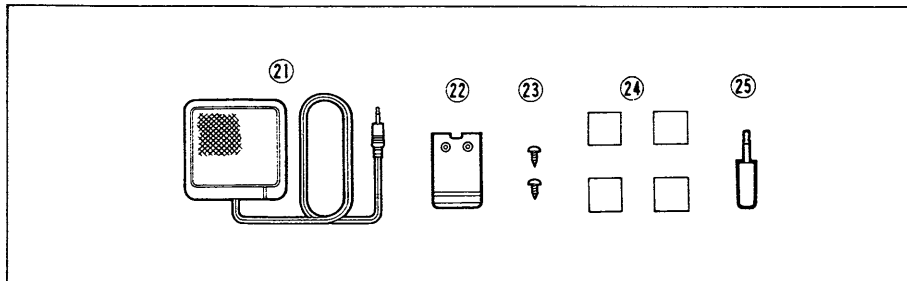

NO.	ITEM	DESCRIPTION
⑳	Speaker (SP-12)	
㉑	Metal grip	Used for mounting the SP-12 to a car sun visor, etc.
㉒	Screws	For attaching the speaker.
㉓	Double-sided tape	For attaching the speaker.
㉔	Speaker plug	For extra speaker connections.

## System upgrading

The IC-901A/E is a dual band transceiver for 144 and 430 (440) MHz bands. By installing optional units to the transceiver, the transceiver will have the following additional capability and features:

- Remote control operation
- 28 MHz operation for Tx and Rx
- 50 MHz operation for Tx and Rx
- 220 MHz operation for Tx and Rx
- 1200 MHz operation for Tx and Rx
- 144 MHz SSB and CW operation
- MW to UHF receiving

Up to 6 separate band units can be connected and used with the IC-901A/E, systematically upgrading the degree of transceiver versatility with every new band unit added. 4 different system settings are possible. See p. 4 for example settings.

## Full option multi-bander system

The following diagram shows the multi-bander system with all optional band units. The IC-901A/E system covers transmitting and receiving between 28 ~ 1200 MHz. Especially the system can operate in FM, LSB, USB and CW modes on the 144 MHz band. In addition, the system functions as a general coverage receiver from the MW to the UHF band.

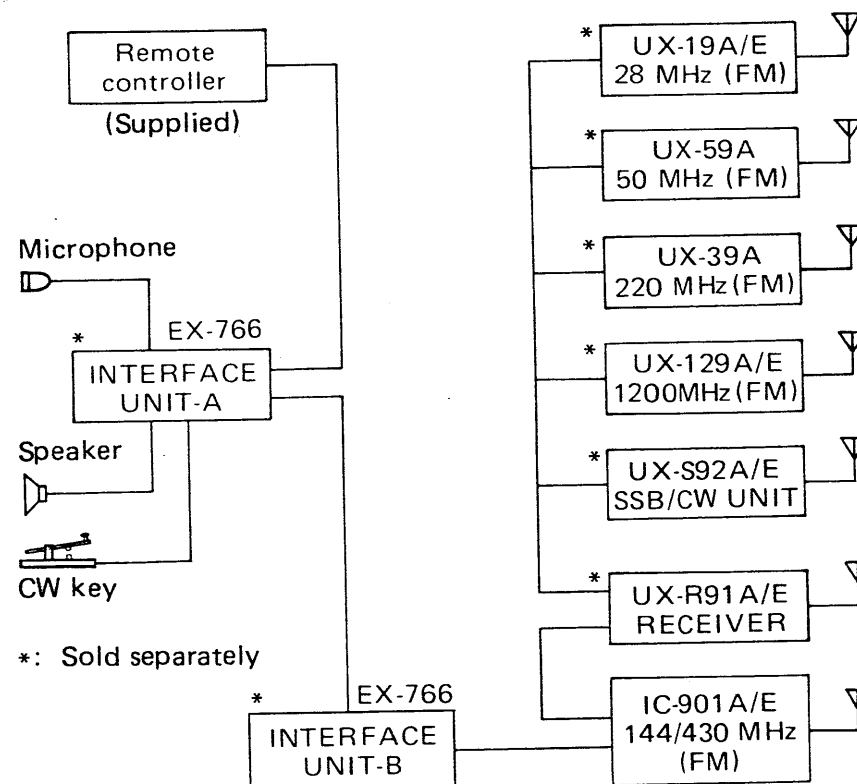

## Optional unit outline

OPTIONAL UNIT	FREQUENCY RANGE	MODE	OUTPUT POWER		REMARKS
			HIGH	LOW	
UX-19A/E	28.00 ~ 30.00 MHz	FM	10 W	1 W	These are additional band units. By adding these units, operating bands are increased. Up to 4 units can be connected with the IC-901A/E.
UX-59A	50.00 ~ 54.00 MHz		10 W	1 W	
UX-39A	*216.00 ~ 236.00 MHz (Receive) 220.00 ~ 225.00 MHz (Transmit)		25 W	5 W	
UX-129A/E	1240.00 ~ 1300.00 MHz		10 W	1 W	
UX-S92A/E	144.00 ~ 148.00 MHz (UX-S92A) 144.00 ~ 146.00 MHz (UX-S92E)	SSB/CW	25 W	5 W	Operating mode for SSB and CW modes are added to the IC-901A/E FM transceiver.
UX-R91A/E	520~1630kHz, 76~108MHz, 108~137MHz 137 ~ 200 MHz, 200 ~ 236 MHz 300 ~ 500 MHz, 800 ~ 950 MHz	See p. 39.	---	---	Receive frequency range will be expanded.

\* Guaranteed frequency range: 220.00 ~ 225.00 MHz

## System upgrading simulations

- Standard 1-body
- Front panel detachable
- Multi-band and multi-mode
- Longer-separation

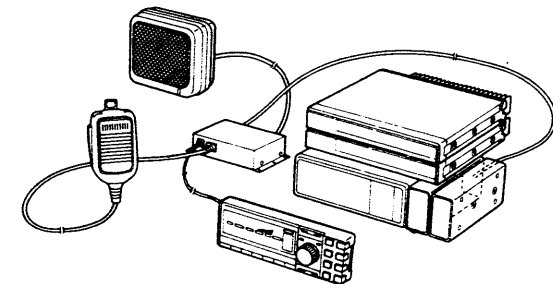
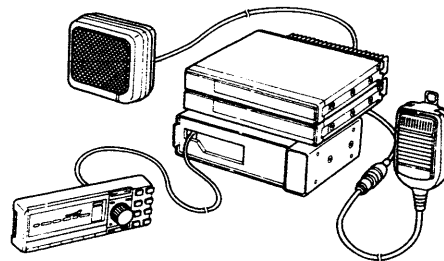
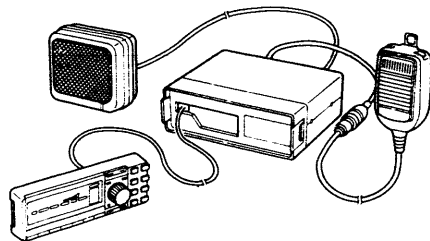
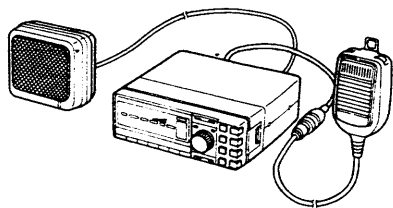

# 3

## PANEL DESCRIPTION

### Front panel

**NOTE:** Pages 5 and 6 describes switches and the control without the SSB/CW unit and receiver unit.

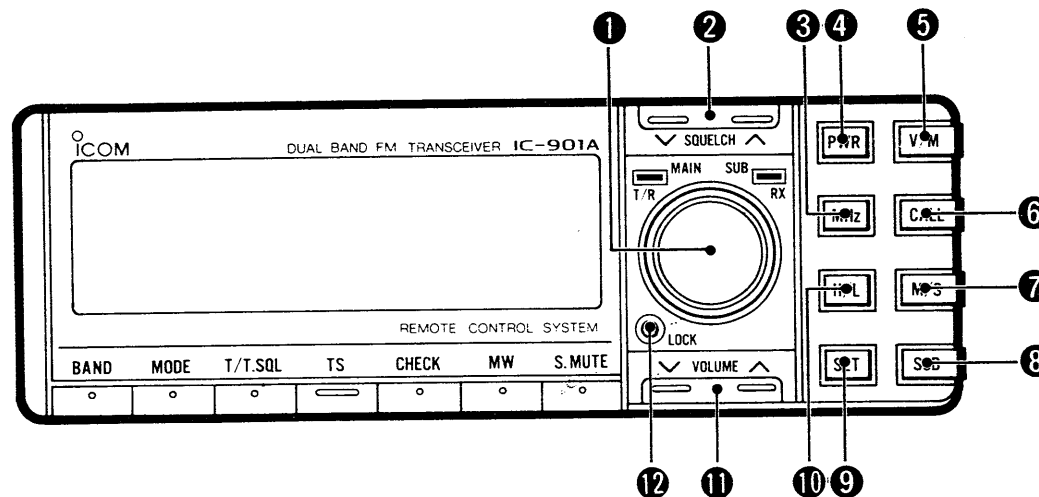

#### 1 MAIN DIAL

- Changes the operating frequency.
- Changes the memory channel.
- Changes contents of the SET mode display.

#### 2 SQUELCH SWITCHES [SQUELCH]

Adjust the squelch threshold level.

#### 3 MHz SWITCH [MHz]

Selects a 1 MHz tuning step increment.

#### 4 POWER SWITCH [PWR]

Turns the power ON and OFF.

#### 5 VFO/MEMORY SWITCH [V/M] (p. 41)

Selects VFO or MEMORY mode.

#### 6 CALL CHANNEL SWITCH [CALL] (p. 43)

Selects a call channel.

#### 7 MAIN/SUB BAND SWITCH [M/S] (p. 27)

Exchanges MAIN and SUB bands.

#### 8 SUB BAND SWITCH [SUB] (p. 27)

Sets the transceiver for operation in the SUB band.

#### 9 SET SWITCH [SET] (p. 52)

Selects SET mode and advances the SET mode displays.

#### 10 TRANSMIT POWER SWITCH [H/L] (pgs. 32, 37)

Selects high or low transmit output power.

#### 11 VOLUME SWITCHES [VOLUME]

Adjust the audio level.

#### 12 LOCK SWITCH [LOCK] (p. 29)

Deactivates the main dial and other switch functions.



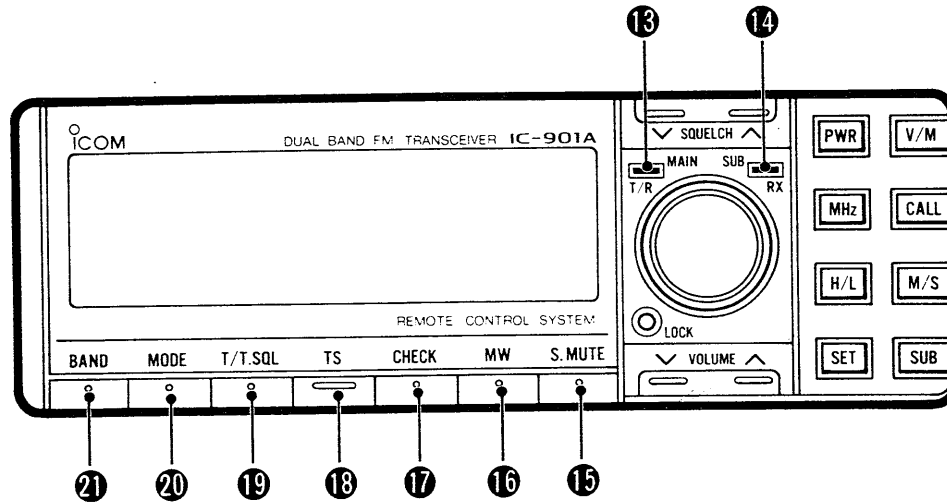

**13 MAIN BAND T/R INDICATOR**

- Lights in green when receiving on the MAIN band.
- Lights in red when transmitting on the MAIN band.

**14 SUB BAND RECEIVE INDICATOR**

- Lights in green when receiving on the SUB band.

**15 SUB BAND MUTE SWITCH [S.MUTE]**

Mutes the sub band audio output.

**16 MEMORY WRITE SWITCH [MW] (pgs. 42, 43)**

- Writes a memory channel.
- Transfers the contents of a memory channel to VFO.
- Programs a call channel.

**17 CHECK SWITCH [CHECK] (p. 33)**

Opens the squelch to check if the frequency is busy or not.

**18 TUNING STEP SWITCH [TS] (p. 29)**

Sets the tuning step at the rate programmed in SET mode.

**19 TONE SWITCH [T/T.SQL] (pgs. 33, 58)**

- Turns ON and OFF the subaudible tone encoder.
- Selects the optional UT-40 function.

**20 MODE SWITCH [MODE] (pgs. 59, 60)**

Selects the pager or code squelch function when the optional UT-48 is installed.

**21 BAND SWITCH [BAND] (p. 28)**

Selects the desired operating band when one or more optional band units are connected.

### 3 PANEL DESCRIPTION

## ■ Rear panel

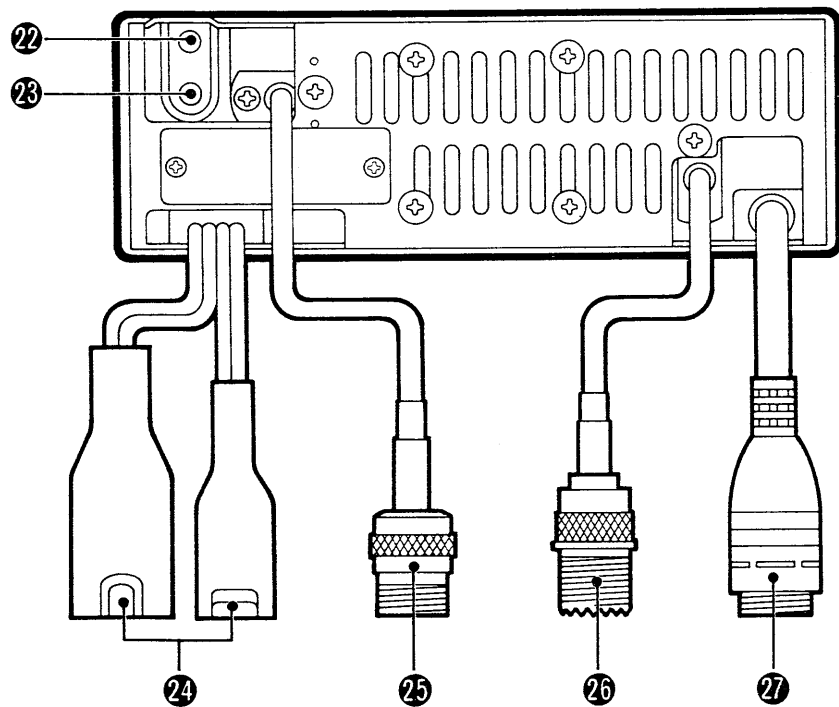

- ②② **MAIN BAND SPEAKER JACK** (pgs. 22 ~ 25)  
Connects the supplied speaker (SP-12) for listening to MAIN band audio.

The speaker jack outputs both MAIN and SUB band audio when no speaker is connected to the SUB band speaker jack item ②③.

- ②③ **SUB BAND SPEAKER JACK** (pgs. 22 ~ 25)  
Connects the optional SP-12 EXTERNAL SPEAKER or suitable speaker for listening to SUB band audio.

**NOTE:** The SUB band speaker jack outputs only SUB band audio. The jack does not output MAIN band audio.

- ②④ **DC POWER CONNECTORS** (p. 19)  
Connects 13.8 V DC using the supplied DC power cable.
- ②⑤ **430 (440) MHz ANTENNA CONNECTOR**  
Connects a 430 or 440 MHz band antenna with a Type-N connector.
- ②⑥ **144 MHz ANTENNA CONNECTOR** (pgs. 21 ~ 24)  
Connects a 144 MHz band antenna with a PL-259 connector.
- ②⑦ **MIC CONNECTOR** (p. 13)  
Connects the supplied microphone or another suitable microphone.

# Microphone

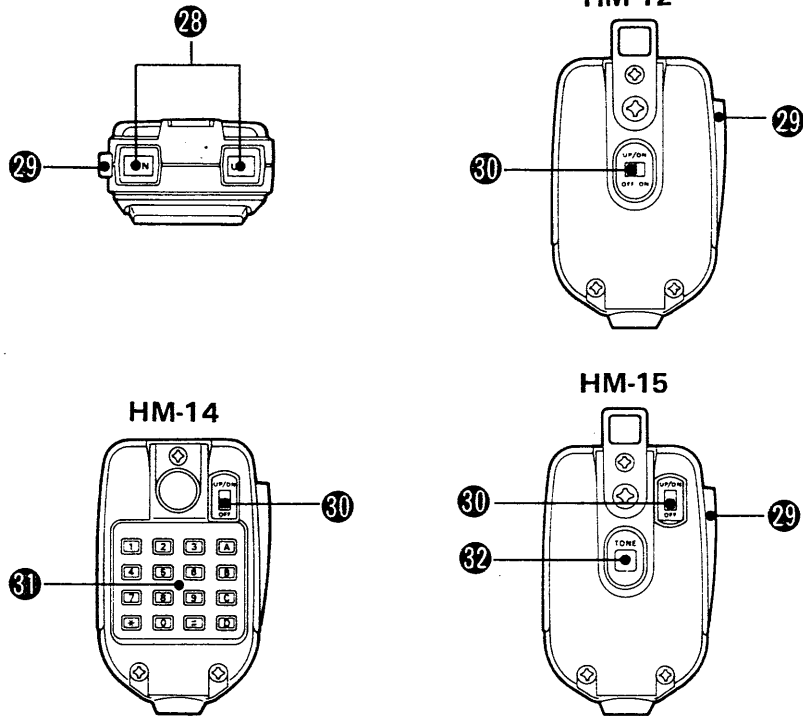

- 28 UP/DOWN SWITCHES**
  - Changes the operating frequency or memory channel.
  - Push and hold either of these switches to start scanning.
- 29 PTT SWITCH**
  - Push to transmit.
- 30 UP/DOWN ON/OFF SWITCH**
  - Prevents accidental frequency changes with the [UP] and [DN] switches.
- 31 DTMF KEYBOARD (HM-14)**
  - Produces DTMF signals while transmitting.
- 32 TONE CALL SWITCH (HM-15)**
  - Transmits a 1750 Hz tone signal.

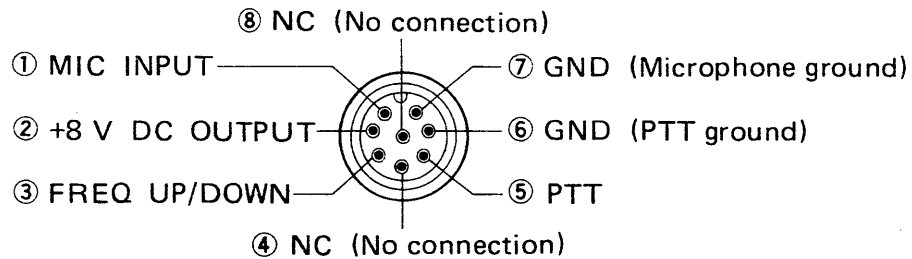

### 3 PANEL DESCRIPTION

## Function display

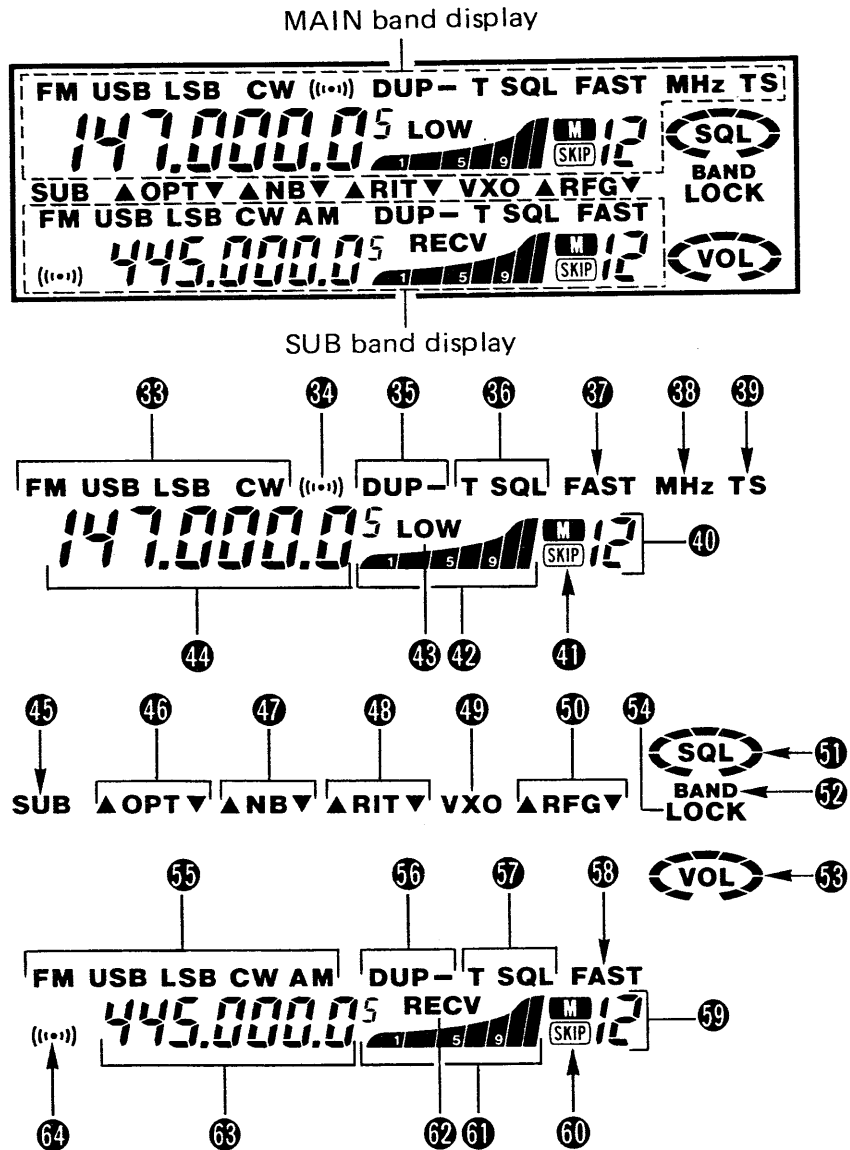

#### 33 MODE INDICATORS

Show the operating mode. USB, LSB and CW modes are optional.

#### 34 POCKET BEEP INDICATOR (optional) (pgs. 57, 58)

Appears when the pocket beep function is activated.

#### 35 DUPLEX INDICATORS (p. 33)

Indicate duplex direction.

#### 36 TONE INDICATORS (pgs. 34, 58)

Indicate subaudible tone encoder or optional UT-40 operating conditions.

#### 37 AGC INDICATOR (optional) (p. 36)

Indicates the AGC time constant for "fast." "FAST" disappears when "slow" is selected.

#### 38 MHz STEP INDICATOR

Indicates when the frequency changes in 1 MHz steps.

#### 39 TS INDICATOR (p. 29)

Indicates when the frequency changes at the rate programmed in SET mode.

#### 40 MEMORY CHANNEL READOUT AND MEMORY INDICATORS (pgs. 41 ~ 43)

- Indicate the memory channel number.
- "M" appears when MEMORY mode is selected.
- "C" appears when a call channel is selected.

- 41 SKIP CHANNEL INDICATOR (p. 48)**  
Appears when a memory channel is programmed as a skip channel.
- 42 S/OUTPUT POWER INDICATORS**
  - Show signal strengths while receiving.
  - Show relative output power selection while transmitting.
- 43 LOW POWER INDICATOR (p. 32)**  
Appears when low output power is selected.
- 44 FREQUENCY READOUT**  
Shows the operating MAIN band frequency except in SET mode.
- 45 SUB BAND INDICATOR**  
Appears when operating on the SUB band.
- 46 OPTIONAL UNIT INDICATORS (optional) (pgs. 58, 59)**  
Appear when the optional UT-40 TONE SQUELCH UNIT is installed.
- 47 NOISE BLANKER INDICATORS (optional) (p. 36)**  
Appear when the noise blanker function is activated.
- 48 RIT INDICATORS (optional) (pgs. 49, 50)**  
Appear when the RIT function is activated.
- 49 VXO INDICATOR (optional) (pgs. 49, 50)**  
Appears when the VXO function is activated.
- 50 RF GAIN INDICATORS (optional) (p. 36)**  
Appear when the RF gain is being set.
- 51 SQUELCH INDICATORS**  
Show the squelch threshold level.
- 52 BAND SCAN INDICATOR (p. 47)**  
Appears during multi-band memory scan.
- 53 VOLUME INDICATORS**  
Show volume level.
- 54 LOCK INDICATOR (p. 29)**  
Appears when the lock function is activated.
- 55 MODE INDICATORS**  
Show the operating mode. USB, LSB, CW and AM modes are options.
- 56 DUPLEX INDICATORS (p. 33)**  
Indicate duplex direction.
- 57 TONE INDICATORS (pgs. 34, 58)**  
Indicate built-in subaudible tone encoder or optional UT-40 operating conditions.

---

## 3 PANEL DESCRIPTION

### 58 AGC INDICATOR (optional) (p. 36)

Indicates the AGC time constant for "fast." "FAST" disappears when "slow" is selected.

### 59 MEMORY CHANNEL READOUT AND MEMORY INDICATORS (pgs. 41 ~ 43)

- Indicate the memory channel number.
- "M" appears when MEMORY mode is selected.
- "C" appears when a call channel is selected.

### 60 SKIP CHANNEL INDICATOR (p. 48)

Appears when a memory channel is programmed as a skip channel.

### 61 S(SIGNAL) INDICATORS

- Show signal strengths while receiving.

### 62 RECEIVER MODE INDICATOR (optional) (pgs. 39, 40)

Appears when the receiver mode is activated.

### 63 FREQUENCY READOUT

Shows the operating SUB band frequency except in SET mode.

### 64 POCKET BEEP INDICATOR (optional) (pgs. 57, 58)

Appears when the pocket beep function is activated.

## Location

Select a location for the transceiver that does not interfere with driving in any way. We recommend the locations shown in the diagram below.

By using the supplied separation cable, the transceiver front panel (remote controller) and transceiver main body can be separated.

**CAUTION:**  
**NEVER** place the transceiver where normal operation of the vehicle may be hindered or where it could cause bodily injury.

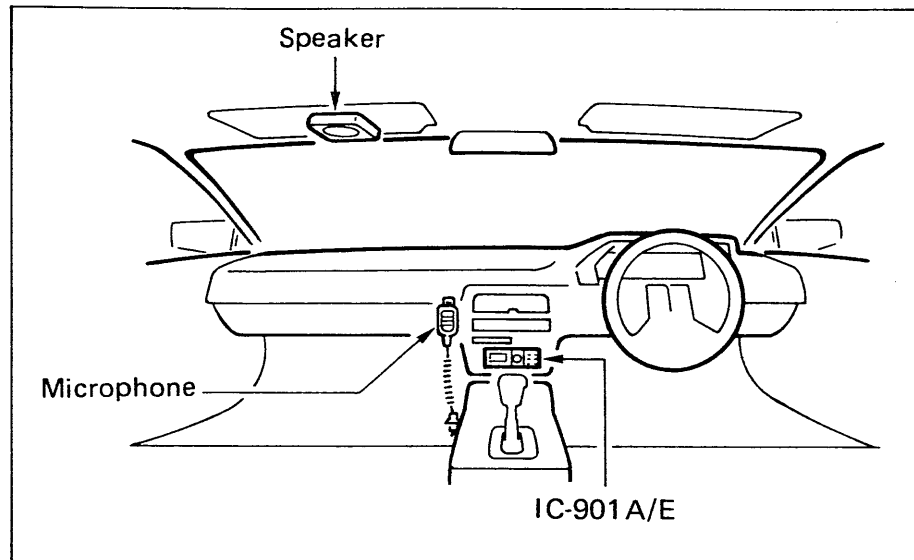

## Mounting the transceiver

- 1) Drill four holes where the mounting bracket is to be installed.
  - Hole sizes:  
 approx. 5.5 ~ 6 mm when using nuts.  
 approx. 2 ~ 3 mm when using self-tapping screws.
- 2) Insert the supplied screws, nuts and washers through the mounting bracket and tighten.
- 3) If the mounting location is not flat, use the supplied mounting bracket.
- 4) Adjust the angle for the clearest view of the function display.

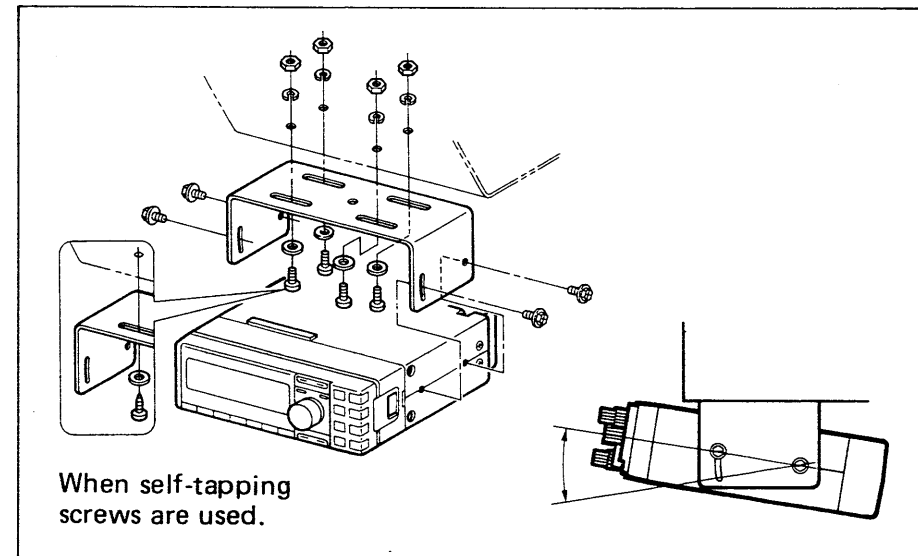

## 4 BASIC INSTALLATION

### ■ Attaching the mic connector

The mic connector should be held to the microphone connector holder to protect the mic connector or mic cable from damage.

**NOTE:** DO NOT allow the mic connector holder to be grounded to any metal parts of the vehicle or RF feedback could occur.

#### ● Attaching the mic connector holder

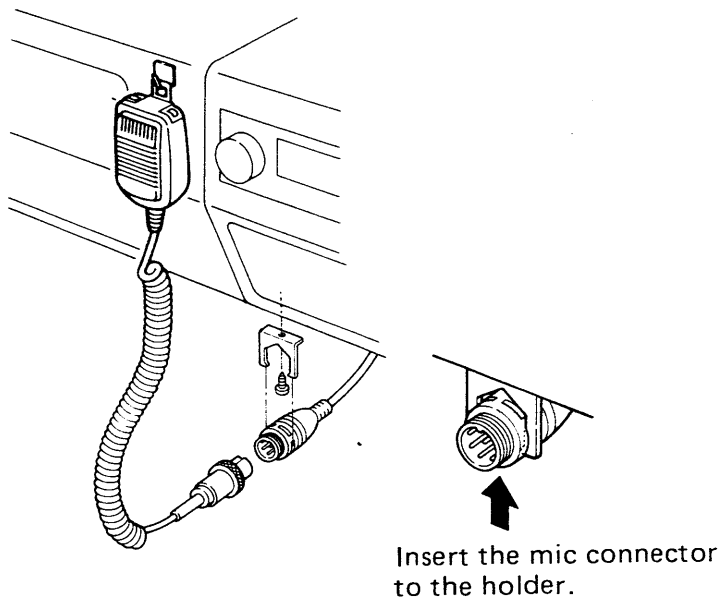

### ■ Attaching the speaker

The supplied speaker can be attached in the following ways:

#### - Sun visor mounting

Attach the metal grip to the back of the speaker with the supplied screws, then clip the speaker to a sun visor in your car.

#### - Dashboard mounting

Mount the speaker in the required position using the supplied double-sided tape (both pieces).

#### ● Installation to the sun visor

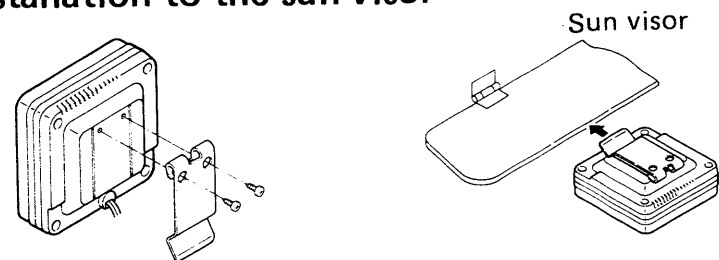

#### ● Installation to the dashboard

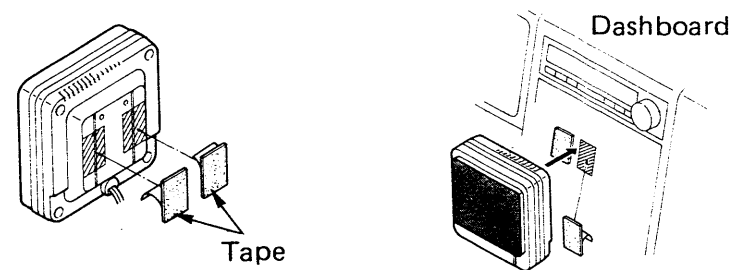



## ■ Separate installation

The remote controller may be placed on your vehicle dashboard or in another convenient place using either the supplied double-sided tape or the remote controller support brackets.

Using the supplied remote control cable (3.5 m, 11.5 ft), the front panel can be separated from the main body, doubling as a remote controller.

### ● Detaching the front panel (remote controller)

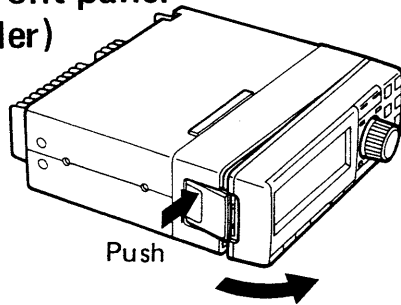

### ● Connecting the remote control cable

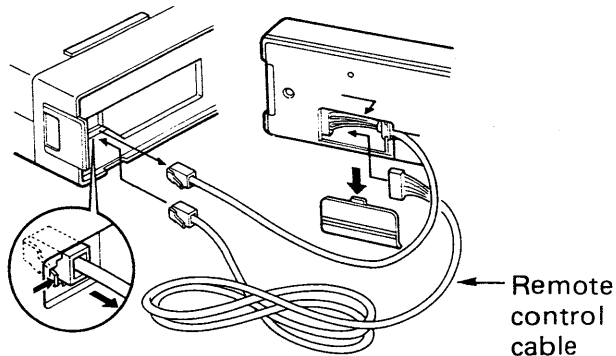

- 1) To separate the remote controller from the transceiver main body, push the latch [PUSH RELEASE].
- 2) Remove the cable cover.
- 3) Disconnect the cable between the remote controller and replace the cable with the supplied longer cable.
- 4) Replace the cable cover.

### ● Installing the remote controller

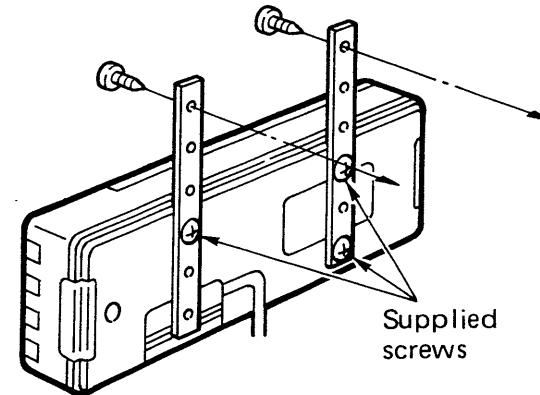

### ● Installation location

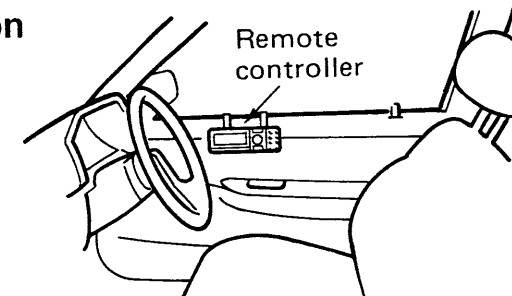

## ■ Non-separated installation

When installing optional band units with the UX-S92A/E or UX-R91A/E, the UX-S92A/E or UX-S91A/E MUST be stacked just above the main body.

- 1) Install the supplied mounting bracket to the floor using the supplied self-tapping screws.
- 2) Pull the front cover of the optional unit forward and remove it.
- 3) Mount the transceiver to the bracket and attach the optional MB-31 STACKING PLATE onto the bracket using the supplied screws.
  - See p. 14 for separate installation procedures.

**NOTE:** Installation of the optional EX-767 CONNECTOR BOX is necessary for installing more than 2 band units.

- 4) Stack band units onto the main body using the stacking plates as shown in the diagram.
- 5) Connect the joint cable between units.
- 6) Cover holes on the top cover of the unit located on top with rubber bushings (L) and (S) to protect the unit from dust.

### ● Connecting joint cables

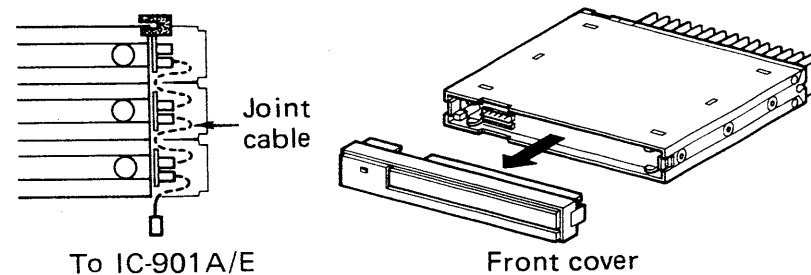

### ● Standard 1-body style installation

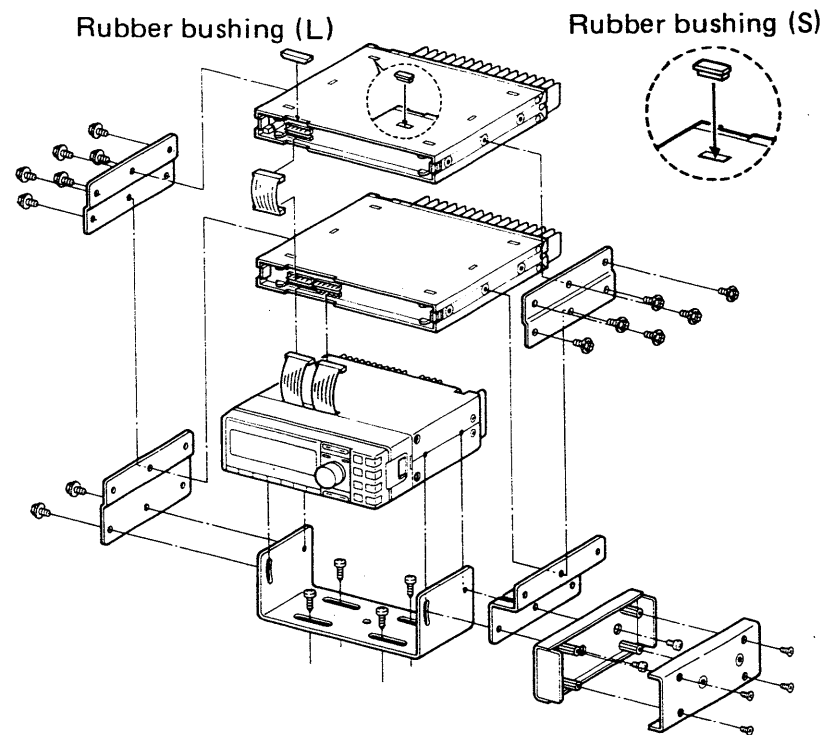

## ■ Separate installation outline

The optional EX-766 OPTICAL FIBER CABLE INTERFACE UNIT can be used for connection between the remote controller and main body. This allows the remote controller to be installed near the driver and the main body to be installed in the trunk.

The following optional units are necessary for installing the main body to the trunk.

- EX-766 OPTICAL FIBER CABLE INTERFACE UNIT
- EX-767 CONNECTOR BOX (when installing more than 2 band units)
- MB-32 MOBILE MOUNTING BRACKET
- OPC-243 DC POWER CABLE

## ■ Pre-work (1)

When installing optional units, the following preparation is necessary in advance.

- 1) Separate the remote controller from the main body.  
See p. 14 for separate installation.
- 2) Unscrew 4 screws on both sides of the main body front cover.
- 3) Connect the joint cable.
  - When installing either UX-S92A/E or UX-R91A/E, connect 2 joint cables to J1 and J5 on the main body.
  - When installing band units, connect the joint cable to J1 on the main body.
- 4) Replace the front cover with screws.

### ● Installation example

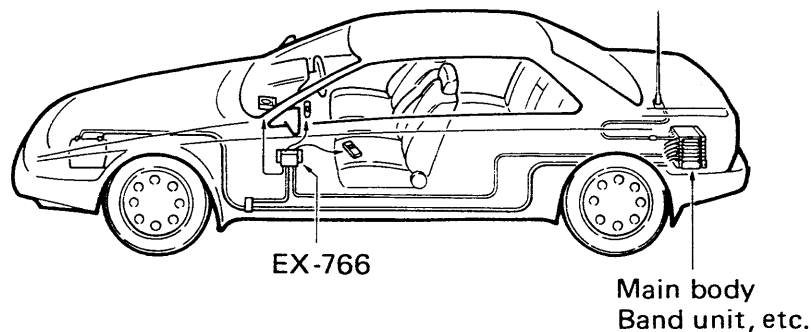

### ● Connecting joint cables

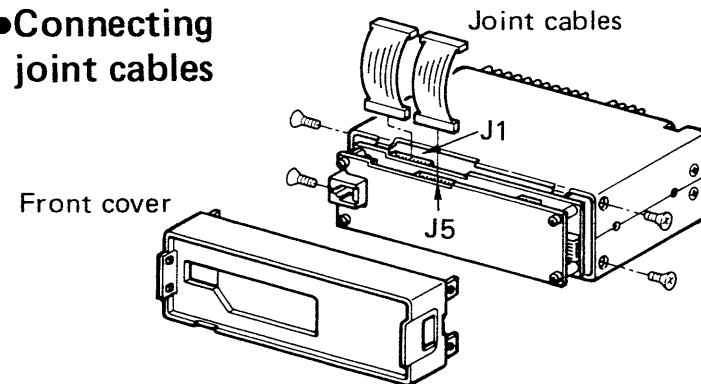

## 5 SYSTEM INSTALLATION

### ■ Pre-work (2)

- 1) Separate the remote controller from the main body and disconnect the cable between the remote controller and the main body.
- 2) Switch S3 to "EX-766" position. (See the diagram at right.)
- 3) Unscrew 4 screws on both sides of the main body front cover and remove the front cover from the body.
- 4) Unscrew 4 screws on the EX-766 INTERFACE UNIT-B and remove the cover as shown in the diagram at right.
- 5) Connect P1 from the EX-766 to J3 on the main body.
- 6) Connect the joint cable.
  - UX-S92A/E or UX-R91A/E installation:  
Connect 2 joint cables to J1 and J5.
  - Band unit installation:  
Connect the joint cable to J1.
- 7) Assemble the front cover. Install the EX-766 INTERFACE UNIT-B to the main body using screws.
- 8) Connect W1 from the EX-766 INTERFACE UNIT-B to J2 on the main body.
- 9) Cover the front cover using the EX-766 FRONT COVER.

#### ● Setting the switch (S3)

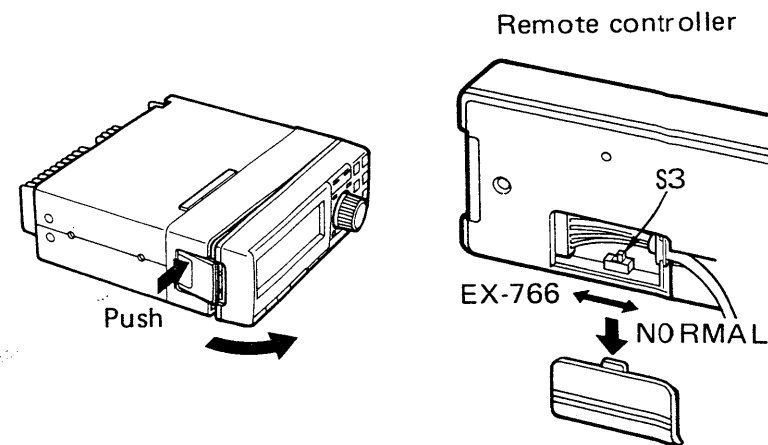

#### ● Pre-work for installing optional units

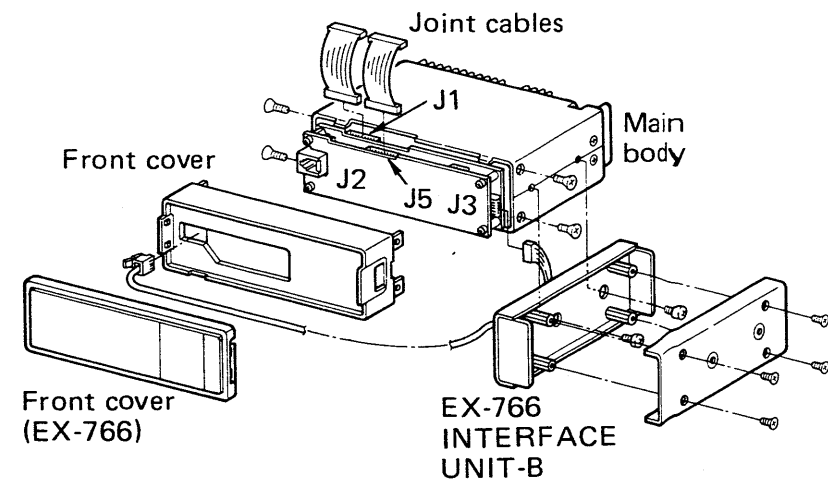

## ■ Mounting in the trunk

The optional MB-32 MOBILE MOUNTING BRACKET is necessary for installing the main body in the trunk. This installation location will not hinder your driving.

- 1) Install the optional EX-766 INTERFACE UNIT-B to the main body in advance. See p. 17 for installation information.
- 2) Install the optional MB-32 MOBILE MOUNTING BRACKET to the floor in the trunk using self-tapping screws.
- 3) Mount the main body to the bracket and attach the stacking plate and optional EX-767 POWER CABLE CONNECTOR BOX using screws.
- 4) Stack an optional unit onto the main body as shown in the diagram at right.
- 5) Cover the top hole on the front cover with a rubber bushing (L) to protect the unit from dust.
- 6) Cover holes on the top cover of the unit located on top with rubber bushings (S) to protect the unit from dust.
- 7) See pgs. 23 and 24 for cable interconnections between units.

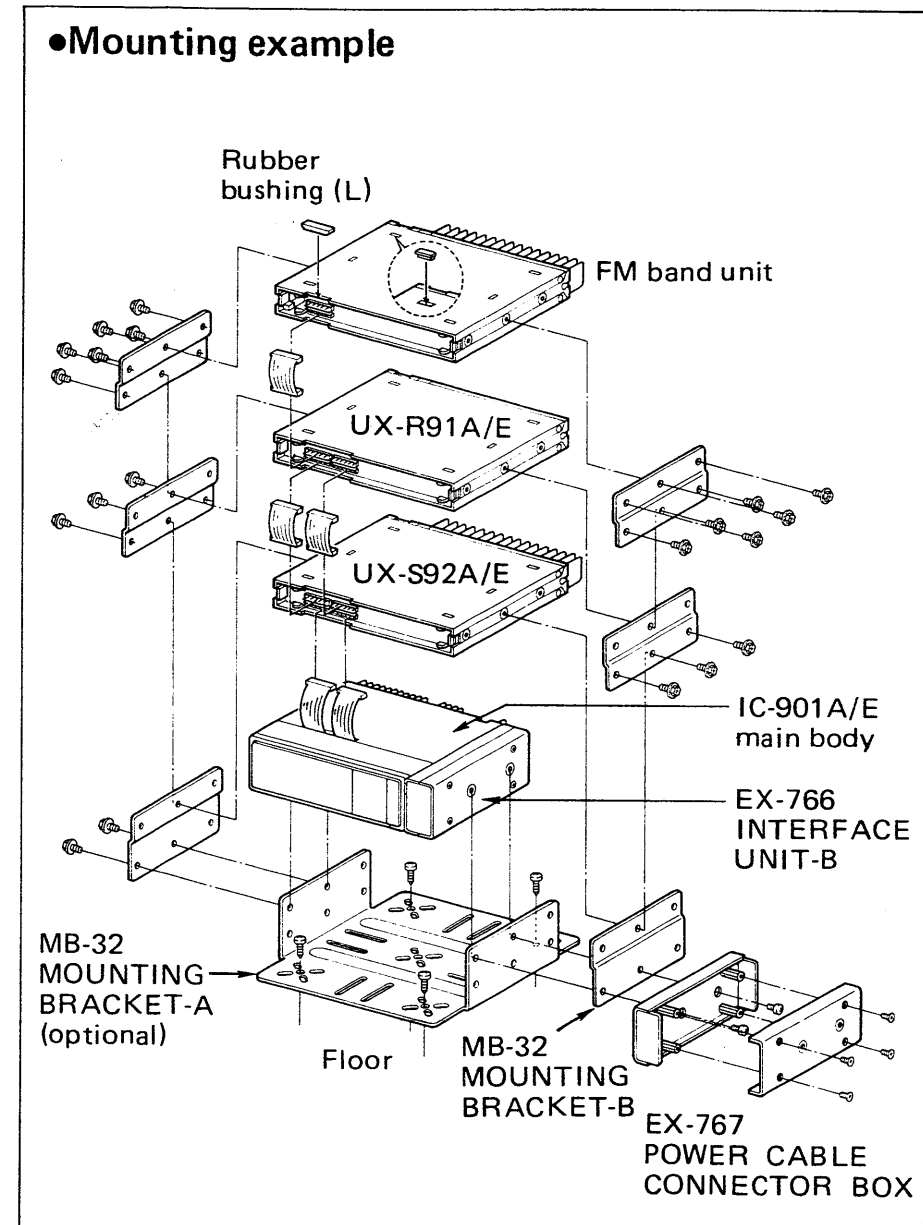

# 6

## REAR PANEL CONNECTIONS

### Battery connection

**CAUTION:** NEVER connect the transceiver directly to a 24 V battery.  
DO NOT use the cigarette lighter socket for power connections.  
To prevent voltage drops, solder or crimp the cable lag when connecting the DC power cable to the battery.

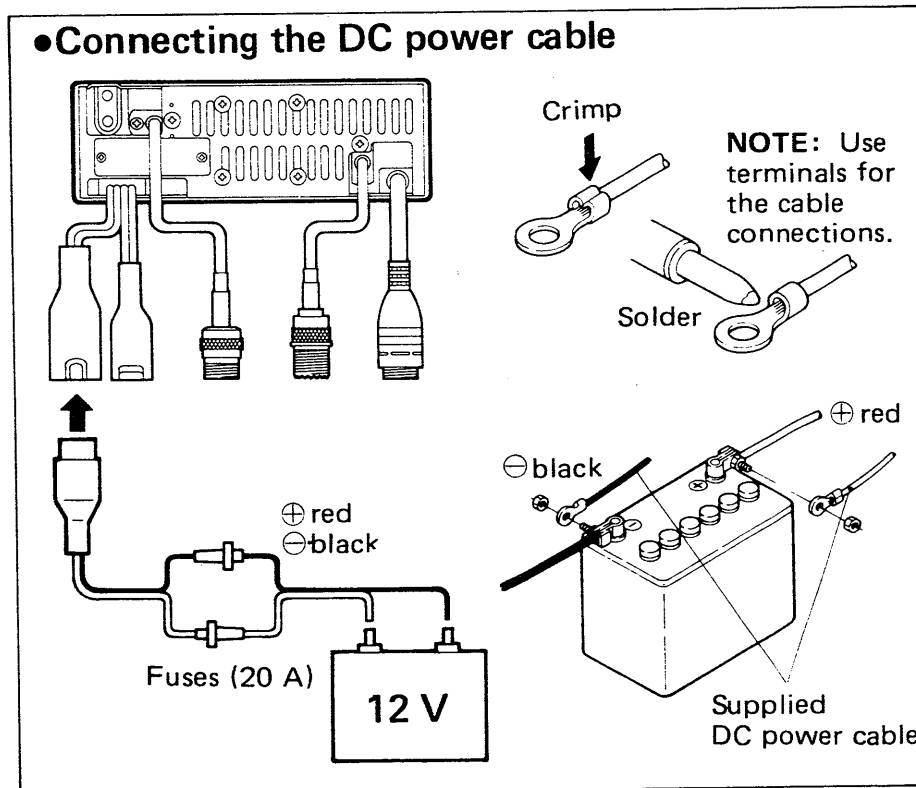

### AC power supply connections

Use a 13.8 V DC power source with more than 12 A capability. The optional Icom IC-PS30 AC POWER SUPPLY is suitable for base station operation.

When using the transceiver as a base station radio, make sure the ground terminal of the power supply is grounded. Use the heaviest gauge wire or strap available and make the connection as short as possible.

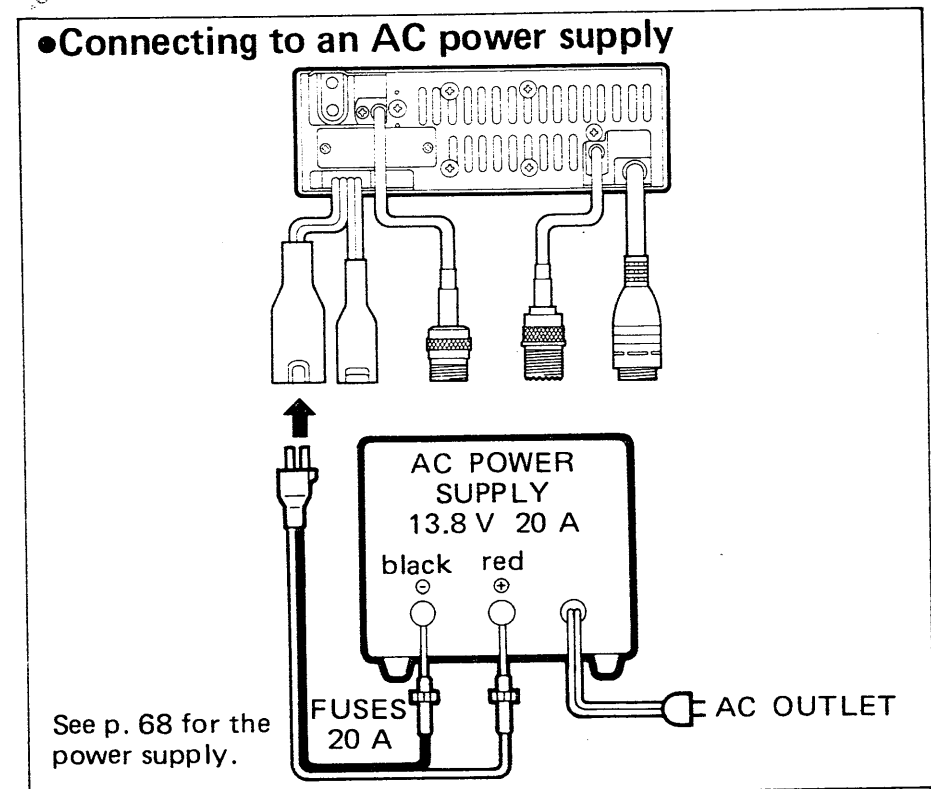

## ■ Antenna connections

The transceiver has 2 antenna connectors installed for the 144 and 430 (440) MHz bands. The transceiver requires two separate antennas for operating without a duplexer.

When using a dual-band or multi-band antenna, a duplexer or antenna splitter must be used.

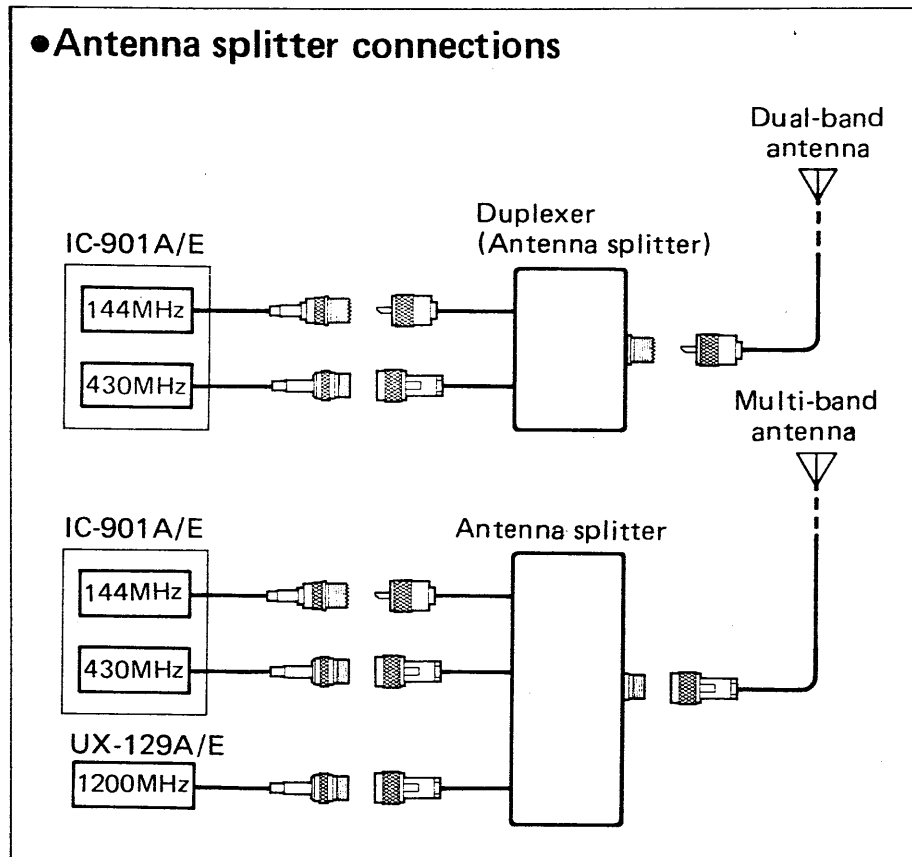

## ■ Optical fiber cable cautions

A reliable, bi-directional optical fiber cable is used to connect the remote controller to the main body. Observe the cautions below when connecting the cable.

### CAUTION:

1. DO NOT bend the optical fiber cable to a radius of less than 25 mm (1 in).
2. DO NOT cut the optical fiber cable.
3. DO NOT bend the optical fiber cable as shown in the diagram.
4. USE the supplied cable clamp to secure the optical fiber cable connection.

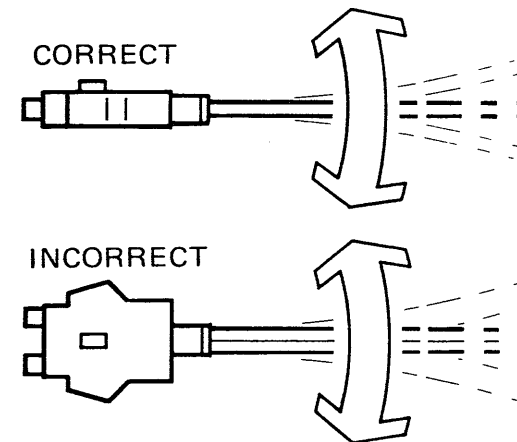

## 6 REAR PANEL CONNECTIONS

### Antenna connector

#### ●PL-259 connector

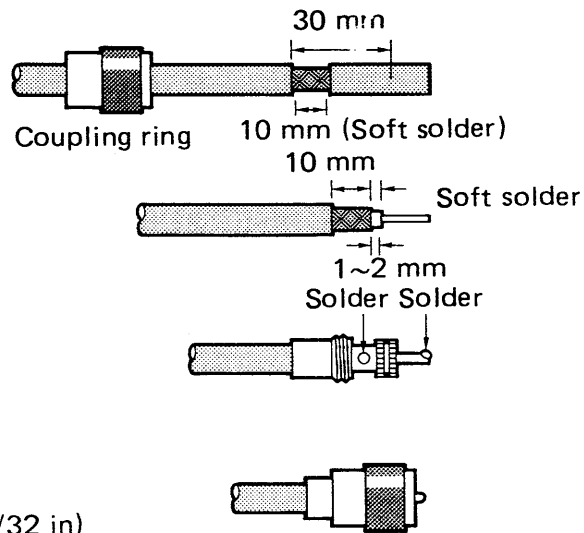

- 1) Slide the coupling ring over the coaxial cable. Strip only the cable jacket and soft solder on the braid.
- 2) Strip the cable as shown above. Tin the center conductor the entire length of the exposed braid.
- 3) Slide the connector body over the cable and solder as shown above.
- 4) Screw the coupling ring onto the connector body.

#### ●Type-N connector

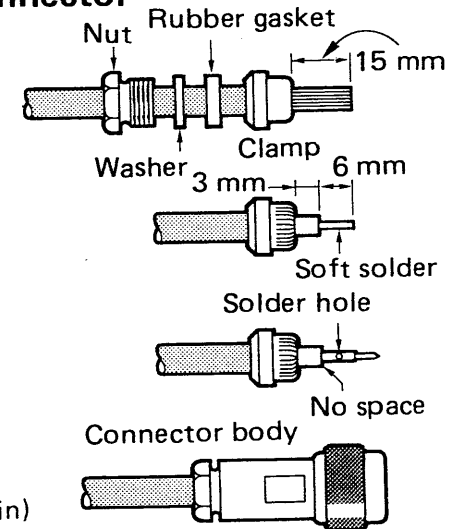

- 1) Slide the nut, washer, and rubber gasket over the coaxial cable and cut the end of the cable evenly.
- 2) Strip the cable and fold the braid over the clamp as shown above. Evenly trim the braid ends.
- 3) Tin the center conductor. Install a center conductor pin and solder it.
- 4) Slide the plug and insert the center conductor pin with the hole inside the connector body. Complete the assembly by screwing the nut onto the connector body.



## Basic connections

With the following connections the IC-901A/E has these capabilities:

- 144 MHz FM mode operation
- 430 (440) MHz FM mode operation

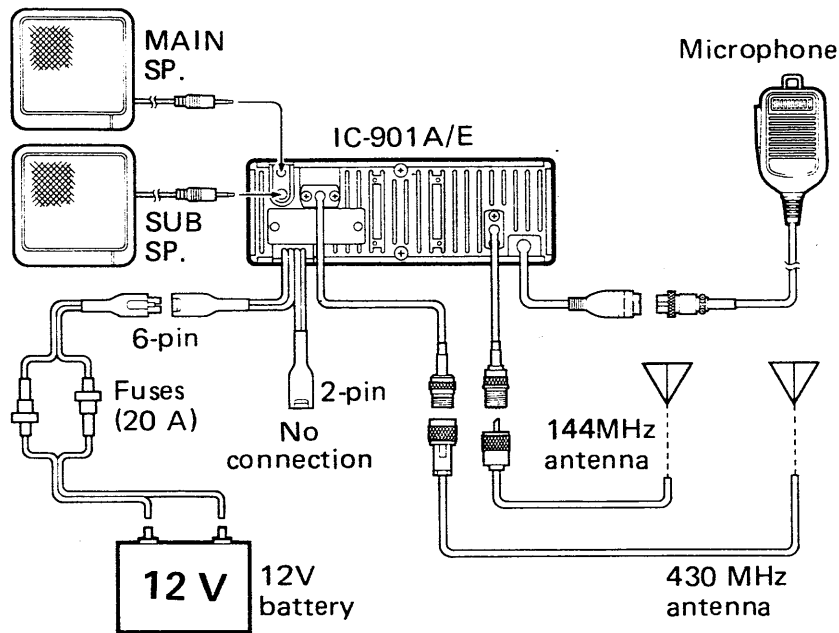

## 1 additional band unit

With the following connections the IC-901A/E has these capabilities:

- 144 MHz FM mode operation
- 430 (440) MHz FM mode operation
- An extra band operation

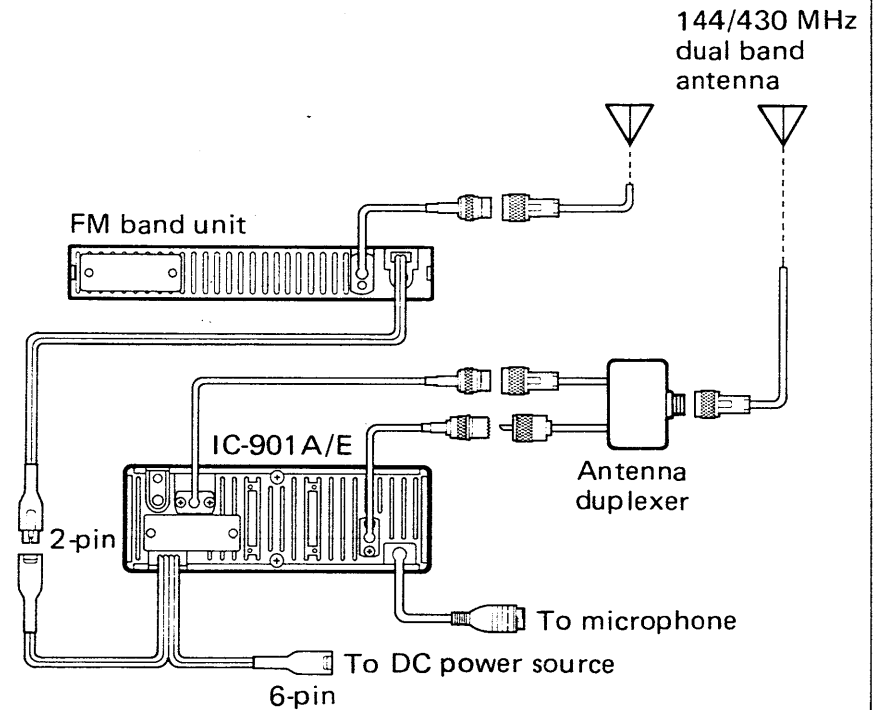

## 7 SYSTEM INTERCONNECTIONS

### ■ UX-S92A/E SSB/CW UNIT

With the following connections the IC-901A/E has these capabilities:

- 144 MHz FM mode operation
- 144 MHz LSB, USB and CW mode operation
- 430 (440) MHz FM mode operation

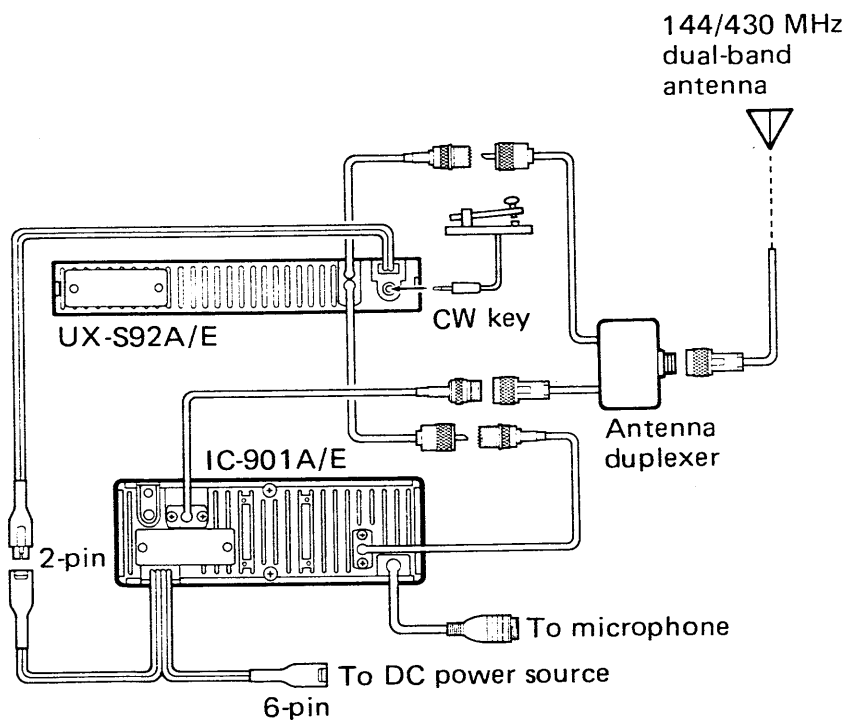

### ■ UX-R91A/E RECEIVER UNIT

The IC-901A/E with following connections has the following capabilities:

- 144 MHz FM mode operation
- 430 (440) MHz FM mode operation
- General coverage receiver for MW, VHF and UHF bands.

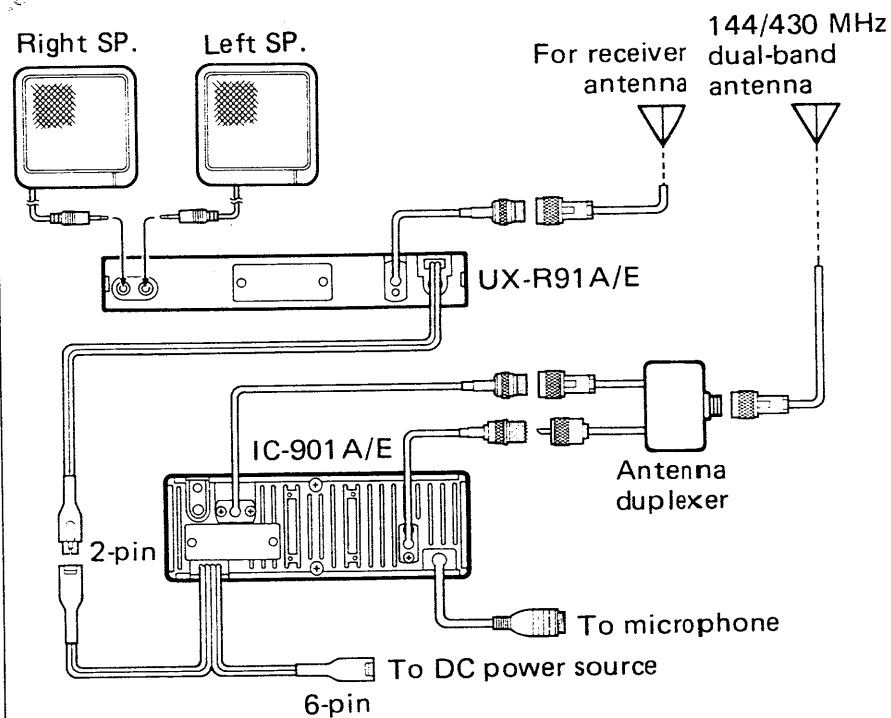

## UX-S92A/E and a band unit

With the following connections the IC-901A/E has these capabilities:

- 144 MHz FM mode operation
- 144 MHz LSB, USB and CW mode operation
- 430 (440) MHz FM mode operation
- An extra band operation

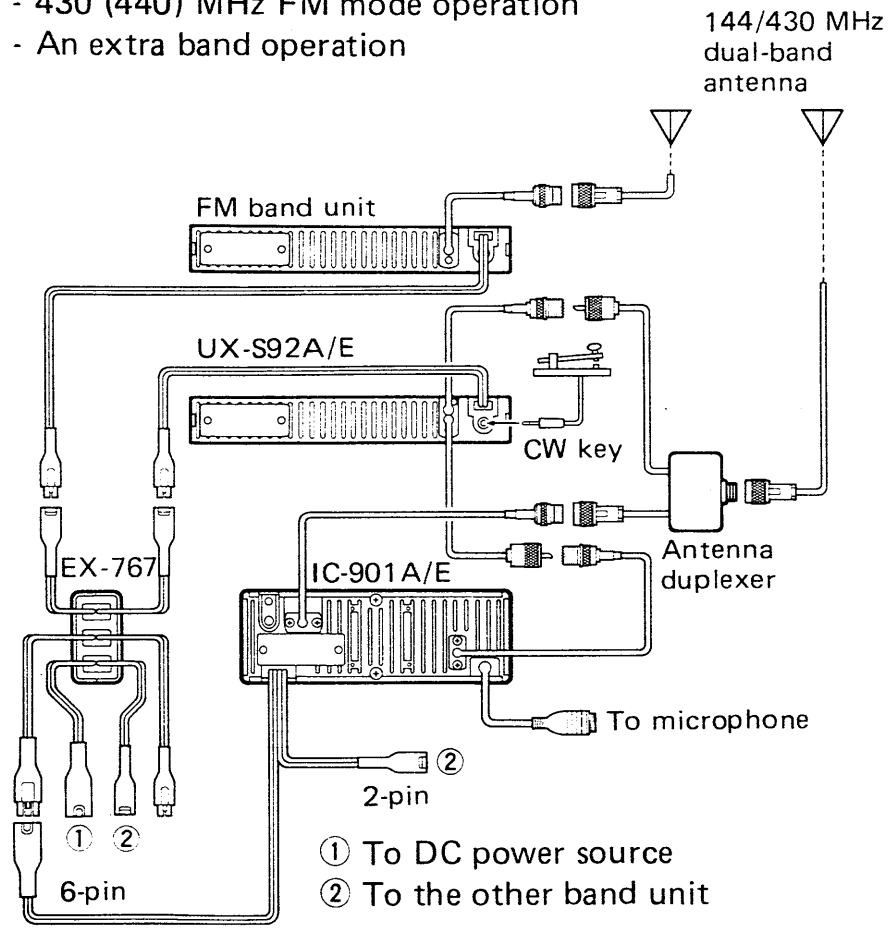

## Optical fiber cable (1)

With the following connections the IC-901A/E has these capabilities:

- 144 MHz FM mode operation
- 144 MHz LSB, USB and CW mode operation
- 430 (440) MHz FM mode operation
- An extra band operation
- General coverage receiver for MW, VHF and UHF bands

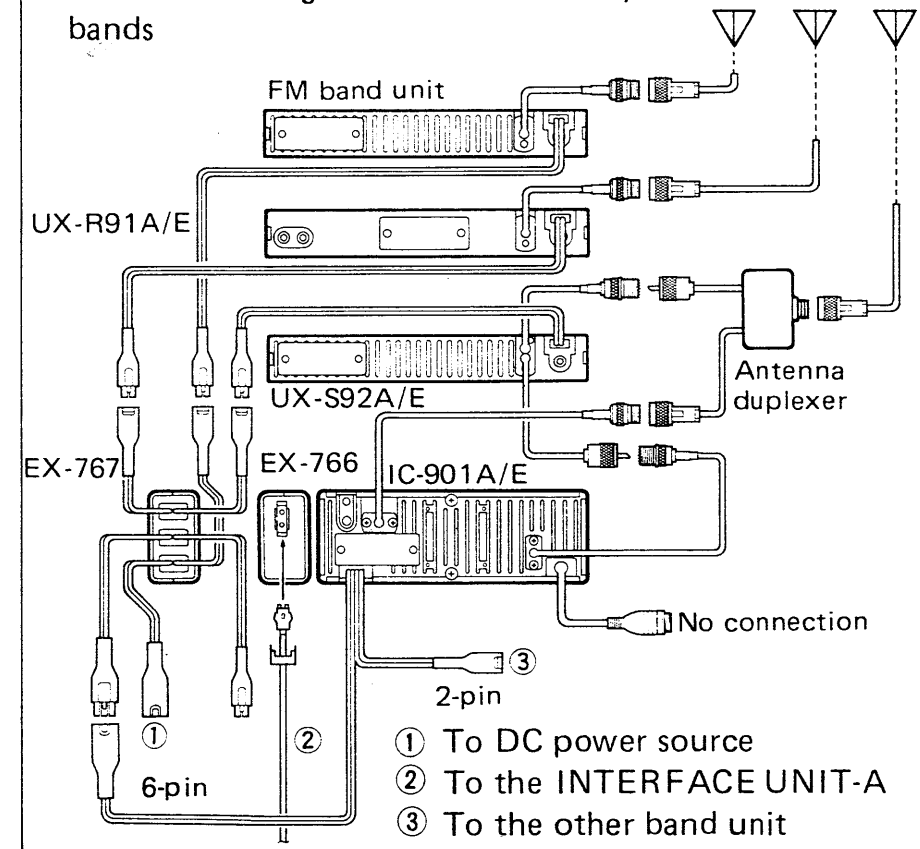

## 7 SYSTEM INTERCONNECTIONS

### ■ Optical fiber cable (2)

When the main body and optional band units are separately installed in your vehicle's trunk through the optical fiber cable, the following connections are necessary. See the diagram at right on p. 24 for all system connections.

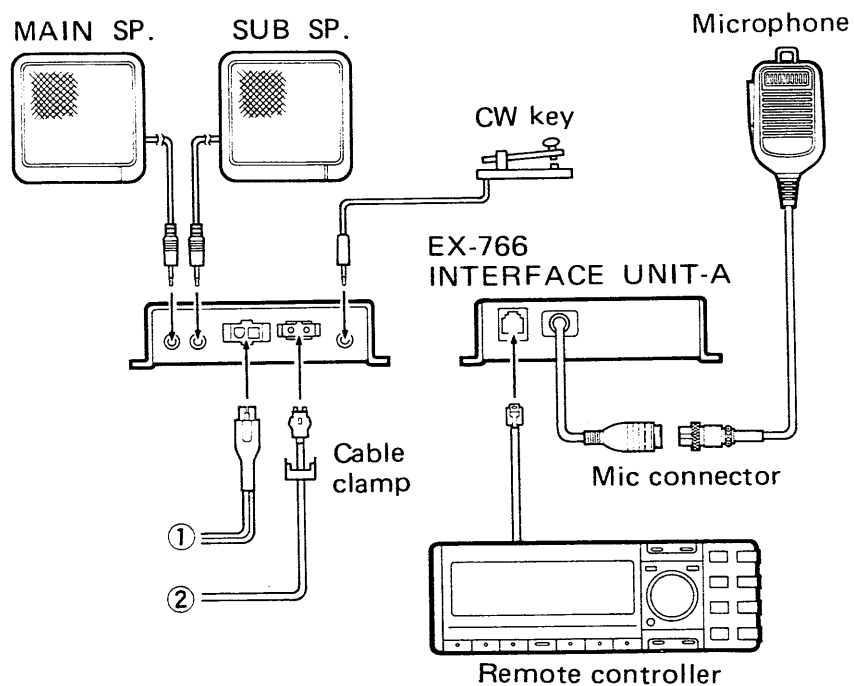

- ① To DC power source
- ② To the INTERFACE UNIT-B (See p. 24)

## Mode types

The IC-901A/E has 4 different modes on each band for versatile, multi-function operations.

MODE	DISPLAY	SWITCH	DESCRIPTION
VFO MODE			<p>This mode is used for general operation.</p> <ul style="list-style-type: none"> <li>To select VFO mode, push [V/M]. "M" disappears.</li> </ul>
MEMORY MODE			<p>This mode is used for operating the transceiver using memory channel contents.</p> <ul style="list-style-type: none"> <li>To select MEMORY mode, push [V/M]. "M" appears.</li> <li>The transceiver has 12 memory channels on each band.</li> <li>Each memory channel can store an operating frequency, offset frequency, etc.</li> </ul>
CALL CHANNEL MODE			<p>This mode provides you with one call channel (separate from memory channels). The call channel is quickly called up with a one-touch button.</p> <ul style="list-style-type: none"> <li>To select CALL channel mode, push [CALL].</li> <li>Each band has one call channel.</li> </ul>
SET MODE			<p>This mode is used for programming infrequently used settings such as tuning step, offset frequency, beep on/off, dimmer on/off, etc.</p> <ul style="list-style-type: none"> <li>To access the SET mode display, push [SET].</li> <li>The SET mode display differs depending on operating modes such as FM, SSB(CW) and RECEIVER modes.</li> </ul>

## 8 PRE-OPERATION

### ■ Exchanging the MAIN and SUB bands

The function display shows both the MAIN and SUB band frequencies simultaneously.

Each push of [M/S] alternately exchanges the MAIN and SUB bands.

**NOTE:** The transceiver receives on the MAIN and SUB band frequencies simultaneously. However, the transceiver transmits only the frequency on the MAIN band display.

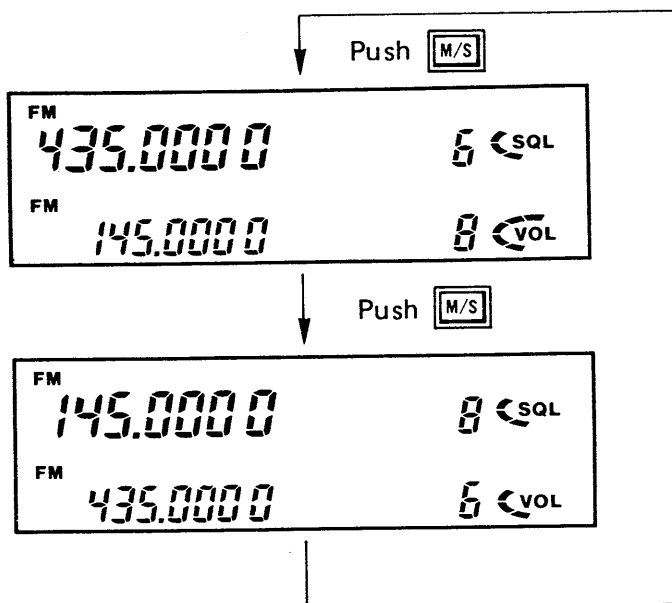

### ■ Accessing the SUB band

The main dial, volume, squelch switches, etc., function during normal operations on the MAIN band. They can also function on the SUB band when the SUB band is accessed.

This function is useful when receiving on the MAIN and SUB bands simultaneously and you want to temporarily receive only on the SUB band.

- 1) Push [SUB] to access the SUB band.
  - "SUB" appears.
- 2) Each push of [SUB] alternately accesses the SUB and MAIN bands.
  - When the SUB band is accessed and no switches or controls are used for 30 seconds, the transceiver automatically returns to the MAIN band.

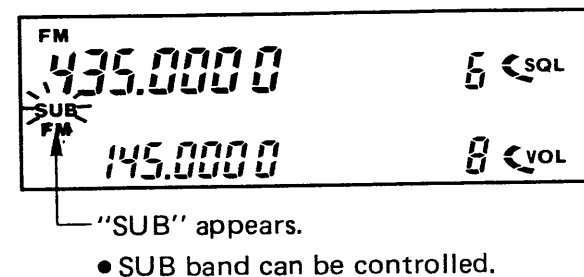

## Selecting the operating band

The operating band can be set with [M/S] when no optional band unit is connected. See p. 27 for instructions.

When an optional band unit is connected, the operating band can be set with [BAND].

- 1) Push [BAND].
  - The band frequency changes on the MAIN band display.
- 2) To set SSB or CW mode in the 144 MHz band, push [BAND].
  - To select FM or SSB/CW mode, push [BAND].

**NOTE:** SSB/CW and FM modes cannot be selected simultaneously in the MAIN and SUB band displays or vice versa.

- 3) To select the desired 2 bands as the MAIN and SUB bands:
  - Select one desired band with [BAND].
  - Push [M/S] to exchange the MAIN and SUB bands.
  - Select the other desired band with [BAND].

### • Band changing simulation

Following is an example for changing the operating band when an optional UX-19A/E 28 MHz BAND UNIT, UX-S92A/E 144 MHz SSB/CW BAND UNIT and UX-129A/E 1200 MHz BAND UNIT are connected.

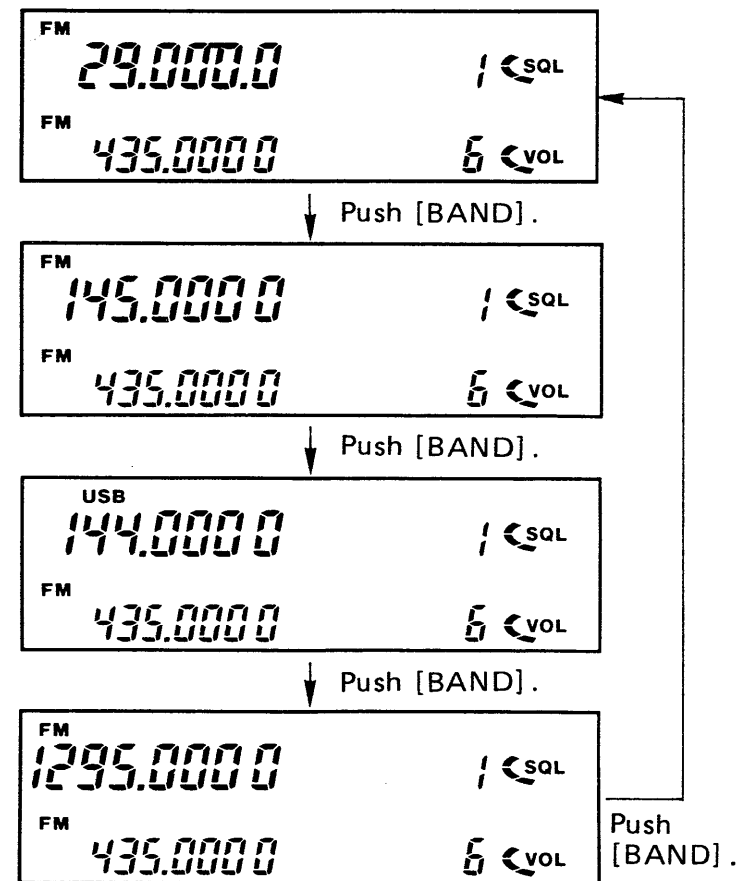

## ■ Setting the operating frequency

Frequency setting is possible only in VFO mode.

- 1) Push [V/M] to select VFO mode.
  - "M" disappears.
- 2) Rotate the main dial or push [UP] or [DN] on the microphone to change the frequency.
  - Push and hold [UP] or [DN] for more than 1 second to activate the scan.
  - To stop the scan, push [UP] or [DN] again.
- 3) To change tuning steps, push [TS].
  - To change the default values of tuning steps, see p. 30.

## ■ Turning on/off the lock function

This function deactivates the main dial and some switches to prevent accidental changes.

- 1) Push [LOCK] to turn ON the function.
  - "LOCK" appears.
  - [VOLUME], [SQUELCH], [CHECK], [S•MUTE] and the PTT switch are not locked.
- 2) Push [LOCK] again to unlock.

## ■ Changing the tuning step

The tuning steps differ depending on operating modes such as FM, SSB (CW) or RECEIVER mode, and can be changed with [TS] on the front panel. Each operating mode has tuning steps indicated below as a default value. See p. 39 for tuning step information when operating in RECEIVER mode.

### ● FM mode tuning step combinations

28/50/220 MHz		144 MHz		430/440 MHz		1200 MHz	
TS-A	TS-B	TS-A	TS-B	TS-A	TS-B	TS-A	TS-B
10	5	10	5	10	5	10	20
15	5	15	5	20	10	20	10
20	10	20	10	25	5	25	12.5
25	5	25	12.5	25	12.5	12.5	25

Unit : kHz

### ● SSB/CW mode tuning step combinations

The transceiver has 3 kinds of tuning steps for TS-A, TS-B and TS-C in SSB or CW mode. Push [TS] to alternately select each tuning step described below.

144MHz	
TS-A	TS-B
50 Hz	1 kHz
100 Hz	1 kHz
1 kHz	50 Hz
1 kHz	100 Hz

### TS-C:

5 kHz steps (fixed) are selected when "TS" appears and a decimal point flashes.



USING SET MODE

Frequency tuning steps are set as default values at the factory as shown in the table on p. 29. However, the tuning steps can be changed as follows:

- 1) Push [SET] several times until "TS" flashes.
- 2) Rotate the main dial for the desired combination of tuning steps.
  - Left number : Tuning steps when "TS" disappears.
  - Right number : Tuning steps when "TS" appears.

**Left number (TS-A):**  
Frequency changes in 20 kHz steps when "TS" disappears.

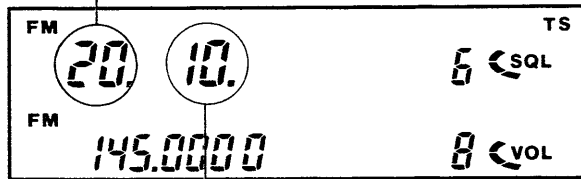

**Right number (TS-B):**  
Frequency changes in 10 kHz steps when "TS" appears.

● **FM mode tuning step**

20 kHz, 10 kHz

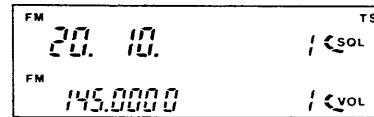

25 kHz, 12.5 kHz

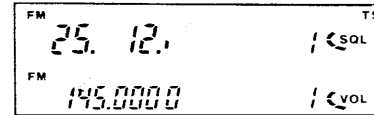

10 kHz, 5 kHz

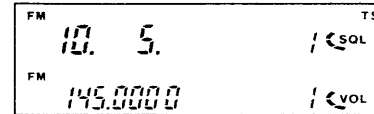

15 kHz, 5 kHz

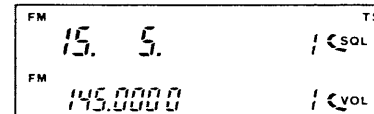

25 kHz, 5 kHz

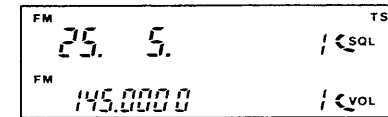

12.5 kHz, 25 kHz

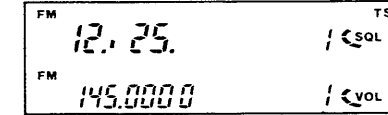

**NOTE:** See the table on p. 29 for the relationship between each band and tuning steps.

● **SSB/CW mode tuning step**

50 Hz, 1 kHz

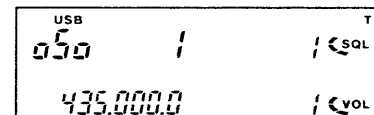

100 Hz, 1 kHz

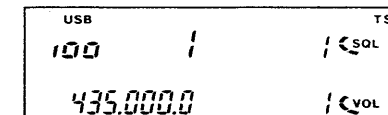

1 kHz, 50 Hz

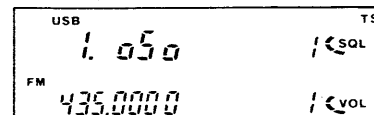

1 kHz, 100 Hz

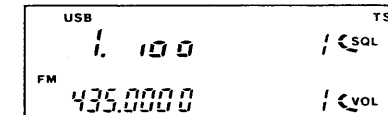

## ■ Watching two frequencies simultaneously

The IC-901A/E has a dual watch function which receives two different frequencies simultaneously. Full duplex operation is possible when setting two different frequencies in different bands.

This function covers FM, SSB/CW and RECEIVER modes.

- 1) Connect 2 speakers for the MAIN and SUB bands to speaker jacks on the IC-901A/E rear panel.
  - When installing the system separately using the optical fiber cable, connect 2 speakers to [SP-1] and [SP-2] on the EX-766 INTERFACE UNIT-A.
- 2) To control SUB band receiving, push [SUB]. Then, control the desired item.
- 3) To receive only the MAIN band frequency, see right for muting the SUB band.

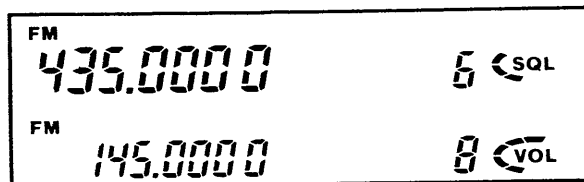

The above display shows that the transceiver receives on 435.0000 MHz and 145.0000 MHz simultaneously.

## ■ Muting the SUB band

When receiving 2 frequencies simultaneously, it is possible to receive only the MAIN band frequency as follows:

- 1) Push [S.MUTE].
  - "VOL" flashes.
- 2) To cancel the function, push [S.MUTE] again.

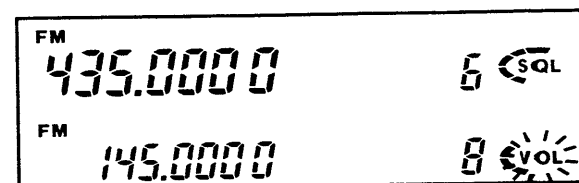

"VOL" flashes when the SUB band is muted.

## ■ Receiving FM signals

The IC-901A/E can display 2 separate bands: the MAIN and SUB bands. Both bands or either band can be received as you desire.

- 1) Push [PWR] to turn ON power.
- 2) Push [M/S] to select the desired band for 144 MHz or 430 (440) MHz as the MAIN band frequency.
  - When a band unit is connected, push [BAND] to select the desired band.
  - See p. 28 for selecting the operating band.
- 3) Push [SQUELCH] to open the squelch.
- 4) Push [VOLUME] to obtain a suitable audio listening level.
- 5) Push [SQUELCH] to close the squelch.
- 6) Set the desired frequency with the main dial or microphone [UP] and [DN] switches.
  - When a signal is received, audio is emitted and the S/RF indicator displays the relative signal strength.
- 7) To receive two different frequencies simultaneously, set both frequencies in the MAIN and SUB bands.
- 8) To change the SUB band frequency, push [SUB].

## ■ Transmitting FM signals

**CAUTION:** Transmitting without an antenna may damage the transceiver.

**NOTE:** The transceiver can transmit only on the MAIN band frequency.

- 1) Set the transceiver in simplex or duplex.
    - See p. 33 for setting simplex or duplex.
  - 2) Set the desired operating band in the MAIN band.
    - Push [BAND] or [M/S] to select the desired band.
  - 3) Push [H/L] to select the desired output power.
    - "LOW" appears : Low power is selected.
    - "LOW" disappears : High power is selected.
- 
- 4) Push the PTT switch on the microphone to transmit.
    - The [TX] indicator lights in red.
    - The RF indicator shows relative output power selection.
  - 5) Speak into the microphone using your normal voice level.
  - 6) Release the PTT switch to receive.

## 10 OPERATING FM MODE

### ■ Operating through a repeater

When operating through a repeater, set the transceiver to duplex. Some repeaters require a subaudible tone superimposed on your transmit signal.

- 1) Set the desired operating frequency for the repeater output frequency on the MAIN band display.
- 2) Set the following contents in SET mode. To set contents, see right.
  - Duplex and the desired duplex direction.
  - Set the desired subaudible tone frequency if needed.
  - Set the required repeater offset frequency if needed.
- 3) Push [T/T.SQL] to turn ON or OFF the subaudible tone encoder if needed.
  - "T" appears when the encoder is turned ON.
- 4) To transmit DTMF signals or 1750 Hz tone call signals, push keys or the tone switch on the microphone respectively. See p. 8 for more information.
- 5) Push and hold the PTT switch to transmit.
  - To return to receive, release the PTT switch.
- 6) To check transmit frequency (repeater input frequency), push [CHECK].
  - This allows checking of the signal strength of your contacted station directly without going through a repeater.

#### USING SET MODE

##### ● Setting duplex

When operating through a repeater, the transceiver should be set in duplex.

- 1) Push [SET] several times until "DUP" appears.
- 2) Rotate the main dial to set simplex or duplex.
  - "DUP" or "DUP—" appears for duplex.
  - No indicator appears for simplex.
- 3) Push [CHECK] to set the condition and to return to the previous display.

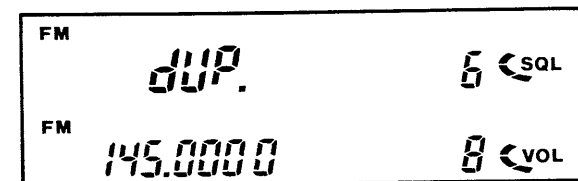

No indicator.  
• Simplex

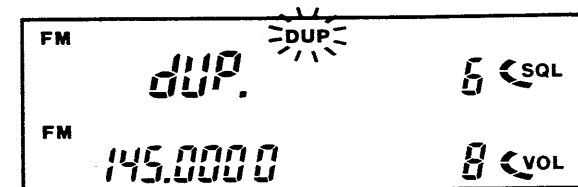

"DUP" appears.  
• +Duplex

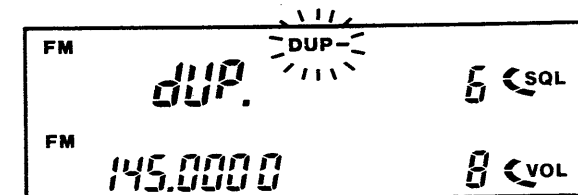

"DUP—" appears.  
• -Duplex

## USING SET MODE

### ●Setting a subaudible tone frequency

Some repeaters require subaudible tones to be transmitted. The transceiver has 37 kinds of tones programmed.

- 1) Push [SET] several times until a tone frequency appears.
- 2) Rotate the main dial to select the desired tone frequency.
- 3) Push [CHECK] to set the value and to return to the previous display.

#### ●Subaudible tones

Unit : Hz

67.0	100.0	136.5	186.2
71.9	103.5	141.3	192.8
74.4	107.2	146.2	203.5
77.0	110.9	151.4	210.7
79.7	114.8	156.7	218.1
82.5	118.8	162.2	225.7
85.4	123.0	167.9	233.6
88.5	127.3	173.8	241.8
91.5	131.8	179.9	250.3
94.8			

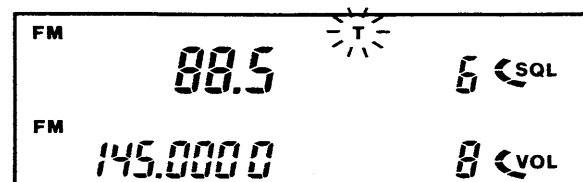

Subaudible tone frequency: 88.5 Hz

## USING SET MODE

### ●Setting an offset frequency

The transceiver is programmed with offset frequencies at 600 kHz as a default value. Change the offset frequency as follows when other than 600 kHz is necessary.

- 1) Push [SET] several times until "DUP" flashes.
- 2) Rotate the main dial to select the desired offset frequency.
  - To select 1 MHz tuning steps, push [MHz].
- 3) Push [CHECK] to set the value and to return to the previous display.

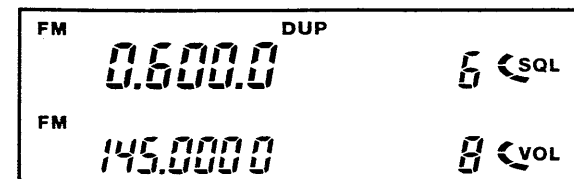

Offset frequency: 600 kHz (Default value)

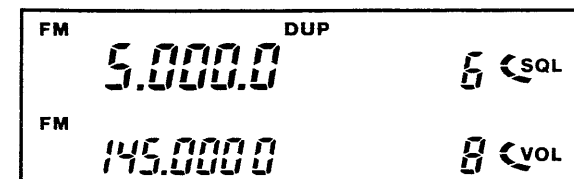

Offset frequency: 5 MHz

# OPERATING SSB/CW MODE (OPTIONAL)

## SSB/CW panel description

When operating in SSB or CW mode in the 144 MHz band, the optional UX-S92A/E is necessary. See pgs. 15 ~ 25 for installation and connection information.

When operating in SSB or CW mode, some switches on the front panel function differently from operation in FM mode.

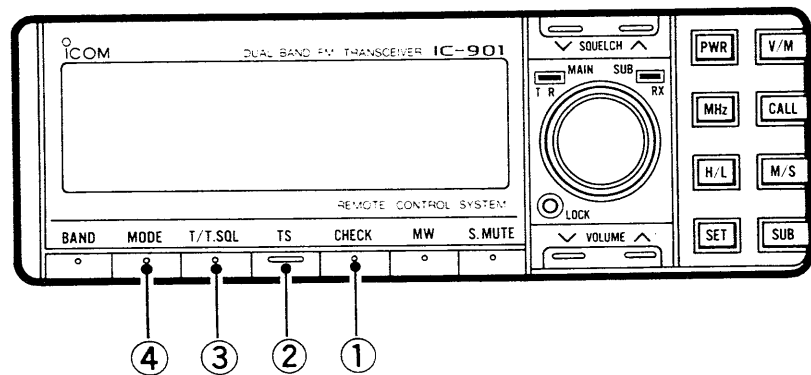

NO.	SWITCH	FUNCTION
①	RF GAIN	Selects one of the 3 RF gain levels.
②	TUNING STEP	Selects the pre-programmed tuning step or RIT/VXO function.
③	NOISE BLANKER	Turns ON and OFF the noise blanker function.
④	MODE	Sets a desired operating mode for USB, LSB or CW.

## Receiving SSB/CW signals

- 1) Push [PWR] to turn ON power.
- 2) Push [BAND] several times until "LSB," "USB" or "CW" appears.
- 3) Push [MODE] to select the desired operating mode.
- 4) Push [SQUELCH] to open the squelch.
- 5) Push [VOLUME] to obtain a suitable audio listening level.
- 6) Push [SQUELCH] to close the squelch if needed.
- 7) Set the desired frequency with the main dial or microphone [UP] and [DN] switches.
  - When a signal is received, audio is emitted from the speaker and the S/OUTPUT POWER indicator displays the relative signal strength.
- 8) To decrease RF gain, push [CHECK]. See p. 36 for more information.
- 9) To change the AGC time constant level from slow to fast or vice versa, see p. 36.
- 10) To turn ON the noise blanker function, push [T/T.SQL].
  - "NB" appears.

●Setting an RF gain level

Decrease the RF gain level when receiving signals in SSB or CW mode and audio output is distorted with strong signals. The RF gain is set at maximum as a default value.

- 1) Push [CHECK] to select one of three RF gain levels.
- 2) Each push of [CHECK] changes the level in 3 different levels. RF gain-1 shows no indicator.

●RF gain-2

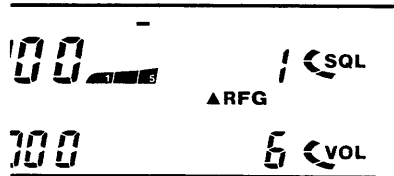

●RF gain-3

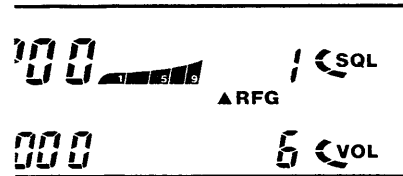

●Noise blanker operation

When receiving signals in USB, LSB or CW mode and the signals include pulse-type noise such as from engine ignitions, use the noise blanker function.

Alternately push [T/T.SQL] to turn ON and OFF the noise blanker function.

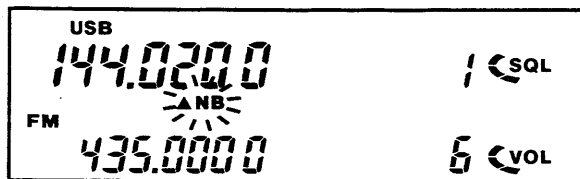

USING SET MODE

●AGC operation

The transceiver has 2 AGC time constant levels for "fast" and "slow." Use either time constant depending on your operating mode.

- 1) Push [SET] several times until "AGC" appears.
- 2) Rotate the main dial to select either fast or slow.
  - "FAST" selection:  
Normally used when receiving a signal with short interval fading. Especially effective in CW mode.
  - "SLOW" selection:  
No indicator appears. Normally used when receiving a signal in USB or LSB mode.
- 3) To return to the previous display, push [V/M] twice.

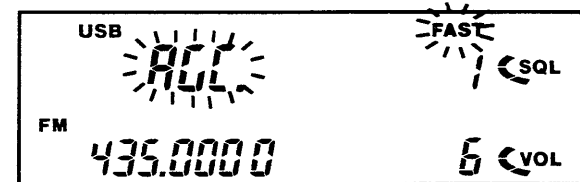

## 11 OPERATING SSB/CW MODE (OPTIONAL)

### ■ Transmitting SSB/CW signals

When operating in SSB or CW mode in the 144 MHz band, an optional UX-S92A/E is necessary. See pgs. 15 ~ 25 for installation and connection information.

**NOTE:** Transmit frequency **MUST** be set on the MAIN band.

#### ● Transmitting SSB signals

- 1) Transmitting should be followed in procedures below after finishing the receiving procedures on p. 35.
- 2) Push [MODE] to select USB or LSB mode.
  - USB mode is usually used in the 144 MHz band.
- 3) Push [H/L] to select the desired output power.
  - High : 10 W No indicator.
  - Low : 1 W "LOW" appears.
- 4) Push and hold the PTT switch to transmit.
  - The [T/R] indicator lights in red.
- 5) Speak into the microphone.
  - The RF bar indicator shows the relative output power level.
- 6) To return to receive, release the PTT switch.

#### ● Transmitting CW signals

- 1) Transmitting should be followed in procedures below after finishing the receiving procedures on p. 35.
- 2) Push [MODE] to select CW mode.
- 3) Connect the CW key to the key jack on the rear panel of the UX-S92A/E.
  - When the system is separately installed using the optical fiber cable, connect the CW key to the [KEY] jack on the EX-766 INTERFACE UNIT-A.
- 4) Push [H/L] to select the desired output power.
  - High : 10 W No indicator.
  - Low : 1 W "LOW" appears.
- 5) Key down the CW key to automatically transmit.
  - The transceiver is automatically set for semi break-in operation when CW mode is selected.

#### ● CW key connections

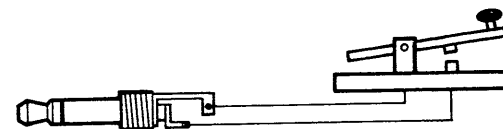



## Adjustment

**CAUTION:** Your IC-901A/E has been thoroughly adjusted and checked at the factory before being shipped. Transceiver warranty does not cover problems caused by unauthorized internal adjustments.

The following adjustment pots shown in the diagram are located in the UX-S92A/E 144 MHz SSB/CW BAND UNIT (optional).

To remove the top cover on the unit, unscrew 2 screws as shown in the diagram below.

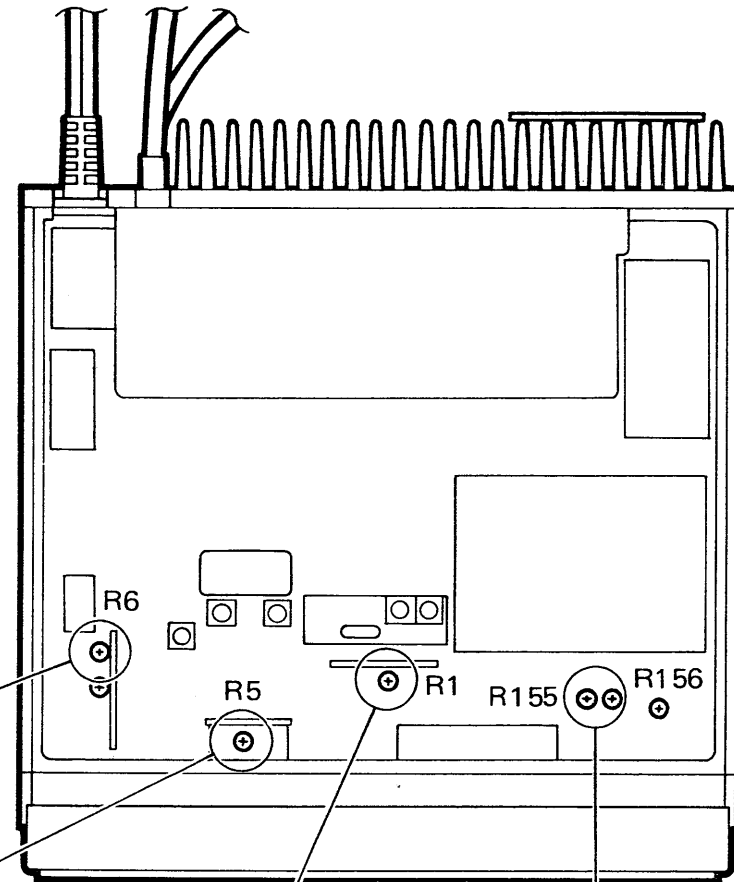
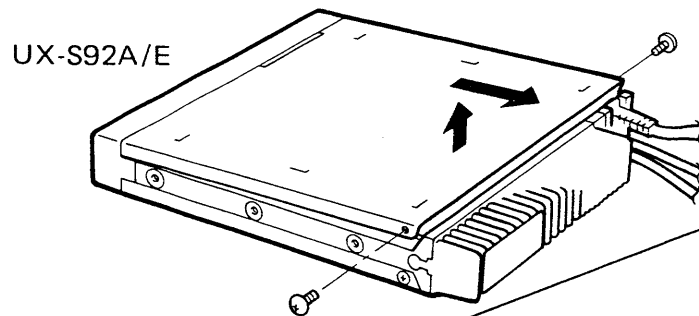

**R6 : CW delay time adj.**  
Changes the Tx-Rx switching time.

Fast  Slow

**R5 : CW sidetone level adj.**  
Changes the CW sidetone level.

Minimum  Maximum

**R1 : Mic gain adj.**  
This adjustment is not effective in FM mode.

Maximum  Minimum

**R155 : RF gain-2 adj.**  
**R156 : RF gain-1 adj.**

Decrease  Increase

### ■ Operation

By connecting an optional UX-R91A/E RECEIVER UNIT to the IC-901A/E, the IC-901A/E can receive the frequency range shown in the table below. See pgs. 15 ~ 25 for installing and connecting the unit.

- 1) Push [SUB] to access the SUB band.
  - "SUB" appears on the function display.

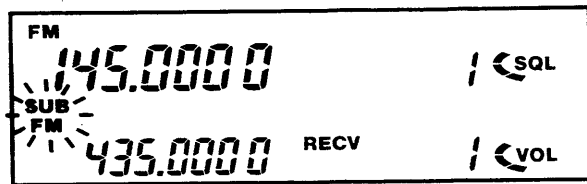

- 2) Push [V/M] to select VFO mode.
  - "M" disappears from the function display.

- 3) Push [BAND] until "RECV" appears.
  - The IC-901A/E is now in the RECEIVER mode.

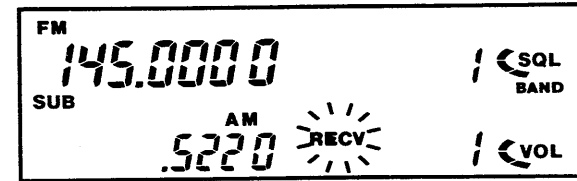

- 4) Push [SET] until "BAND" and frequency appear.

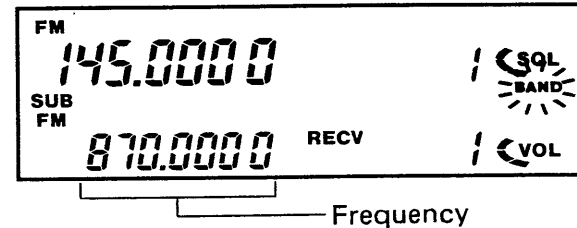

- 5) Rotate the main dial to select the desired receive band.

		MW BAND	VHF BAND				UHF BAND	
FREQUENCY COVERAGE		520 kHz	76.00 MHz	108.00 MHz	137.00 MHz	200.00 MHz	300.00 MHz	800.00 MHz
		1630 kHz	108.00 MHz	137.00 MHz	200.00 MHz	236.00 MHz	500.00 MHz	950.00 MHz
MODE		AM	FM	AM	FM	FM	FM	FM
TUNING STEP (IC-901A)	TS-A	10 kHz	100 kHz	25 kHz	15 kHz	15 kHz	25 kHz	12.5 kHz
	TS-B	1 kHz	10 kHz	12.5 kHz	5 kHz	5 kHz	5 kHz	25 kHz
TUNING STEP (IC-901E)	TS-A	10 kHz	100 kHz	25 kHz	25 kHz	25 kHz	25 kHz	12.5 kHz
	TS-B	1 kHz	10 kHz	12.5 kHz	12.5 kHz	12.5 kHz	12.5 kHz	25 kHz

- 6) Push [CHECK] to set the band and return to the previous operating display.
- 7) Rotate the main dial or push [UP] or [DN] on the microphone to set the desired frequency.
  - Tuning steps are fixed on each band. See the table below.
- 8) Push [VOLUME] to adjust the desired listening audio level.
  - To listen to the stereo signal, see the instructions at right.
  - Volume balance in stereo signal receiving can be adjusted using SET mode. See SET mode at right.
- 9) Push [SQUELCH] to close the squelch, if necessary.

**NOTE:** When RECEIVER mode is selected, the receive band frequency always appears on the SUB band display and cannot be exchanged between the MAIN band frequency and the SUB band frequency with the [M/S] switch.

- 10) RECEIVER mode automatically returns to the MAIN band after no switch is used to control the SUB band for 30 seconds. "SUB" disappears.
- 11) To control the SUB band, push [SUB] again.

## ●Receiver audio output

- To listen to stereo signals in a frequency range between 76 MHz ~ 108 MHz using 2 separate speakers, connect 2 speakers to speaker jacks on the UX-R91A/E rear panel. See SET mode below.
- When no speaker is connected to the UX-R91A/E, receive audio is emitted from the speaker on the IC-901A/E or INTERFACE UNIT-A in monaural.

### USING SET MODE

Volume balance between the right and left speakers can be adjusted when an FM broadcasting station is being received.

- 1) Push [SUB] to access SUB band.
- 2) Push [SET] several times until "bAL" appears.
- 3) Rotate the main dial to adjust the desired balance.
  - The squelch indicator shows the balance level.

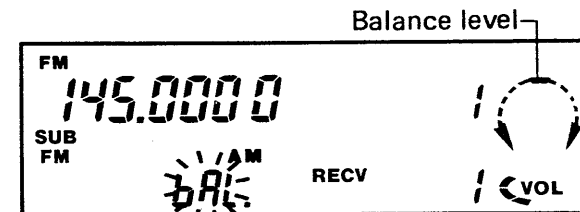

# 13 USING MEMORY CHANNELS

## Memory mode outline

The transceiver has 12 memory channels for each band. Memory channels are very useful for quickly changing to a desired frequency.

Memory channels 1 ~ 10 independently store information as follows, and memory channels 11 and 12 also have the following special memory function:

MEMORY CHANNEL NUMBER	CAPABILITY
1 ~ 10	The following information can be stored in each memory channel. 1. Operating frequency 2. Operating mode 3. *Offset frequency 4. *Tone frequency 5. *Shift direction 6. *Tone encoder on/off 7. *Tone squelch on/off
11 and 12	The same information as above can be stored in each memory channel. In addition, these are used as upper and lower memory channels for the programmed scan.

\*This information can be set in SET mode. See p. 52 for accessing SET mode.

## Selecting MEMORY mode

- 1) Pushing [V/M] alternately changes VFO and MEMORY mode.
- 2) To access the SUB band MEMORY mode, push [SUB] then, push [V/M].
- 3) The SUB band automatically returns to the MAIN band after no switch controls the SUB band for 30 seconds. "SUB" disappears.

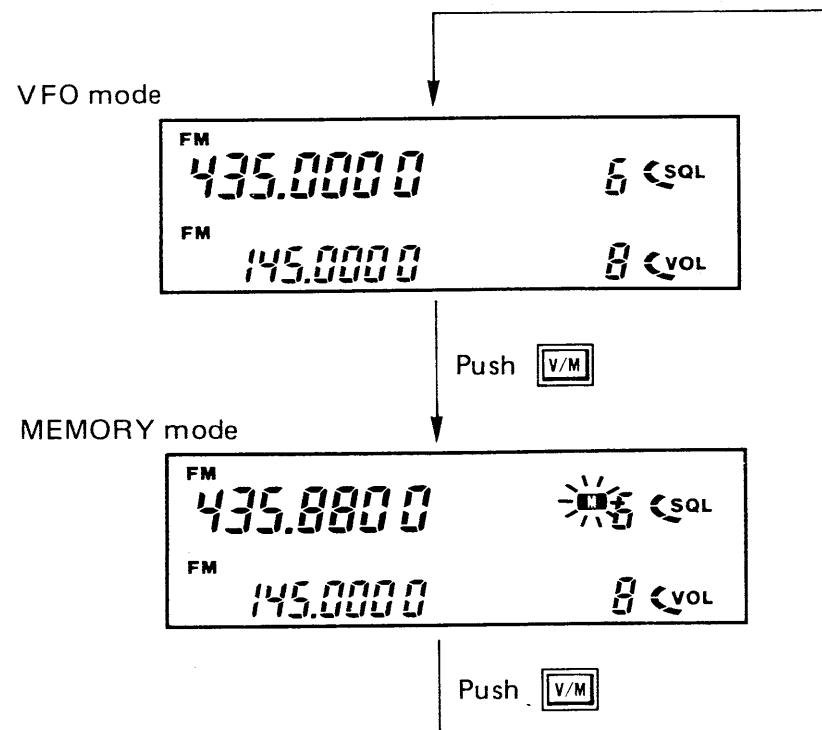

## ■ Selecting a memory channel

- 1) Push [V/M] to select MEMORY mode.
  - "M" appears.
- 2) Rotate the main dial or push [UP] or [DN] on the microphone to select the desired memory channel.
- 3) To return to VFO mode, push [V/M].
- 4) To access the SUB band memory channel, push [SUB] then push [V/M].
  - "SUB" appears.
- 5) Push [V/M] to select MEMORY mode.
  - "M" appears.
- 6) Rotate the main dial or push [UP] or [DN] on the microphone to select the desired memory channel.
- 7) To return to VFO mode, push [V/M].

## ■ Writing a memory channel

- 1) Push [V/M] to select MEMORY mode.
  - "M" appears.
- 2) Rotate the main dial or push [UP] or [DN] on the microphone to select the desired memory channel you wish to store.
- 3) Push [V/M] again to return to VFO mode.
  - "M" disappears.
- 4) Set the desired frequency you wish to store.
  - Skip to step 7 when no information in SET mode is changed.
- 5) To store repeater information such as subaudible tone frequency, offset frequency etc.:
  - Push [SET] to access SET mode.
  - Then, set the desired contents using SET mode. See pgs. 52 ~ 54 for changing contents using SET mode.
- 6) Push [V/M] until the display returns to VFO mode.
- 7) Push and hold [MW] until the speaker emits 3 beep tones to store the information.

## 13 USING MEMORY CHANNELS

### ■ Transferring a frequency

Copy and transfer the displayed memory contents into the VFO. This function is useful for searching for signals around the memory channel frequency. Memory channel contents are not erased.

- 1) Push [V/M] to select the MEMORY mode.
  - "M" appears.
- 2) Rotate the main dial or push [UP] or [DN] on the microphone to select the desired memory channel.
- 3) Push and hold [MW] until the speaker emits 3 beep tones.
  - The memory information is transferred from the displayed memory channel to VFO mode.

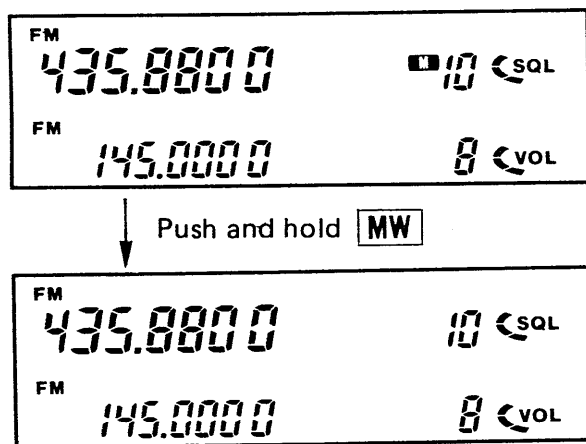

### ■ Operating the call channel

The transceiver has an independent call channel for each band to easily select your most-used frequencies.

#### ● Recalling the call channel

- 1) Push [CALL] to select a call channel.
  - "C" appears.
  - The main dial is deactivated.
- 2) To return to VFO or MEMORY mode, push [CALL] or [V/M] again.

#### ● Programming a call channel

- 1) Push [V/M] to select VFO mode.
- 2) Set the desired frequency as a call channel.
  - Skip to step 4 when no information in SET mode is changed.
- 3) Set the other information in SET mode. See pgs. 52 ~ 54 for accessing SET mode.
- 4) Push [CALL] to select CALL channel mode.
  - "C" appears.
- 5) Push and hold [MW] until the speaker emits 3 beep tones.
  - The information is now stored as a call channel.

## Scan types

There are 3 scan types. Each scan functions in both the MAIN and SUB bands. The memory skip function is used with memory scan.

### ●Programmed scan

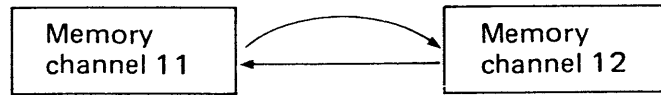

Repeatedly scans between two user-programmed scan edges for memory channels 11 and 12 in either the MAIN or SUB band.

### ●Memory scan

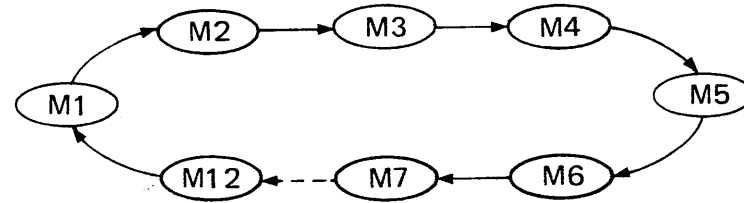

Repeatedly scans all memory channels 1 to 12 in either MAIN or SUB band.

### ●Multi-band memory scan

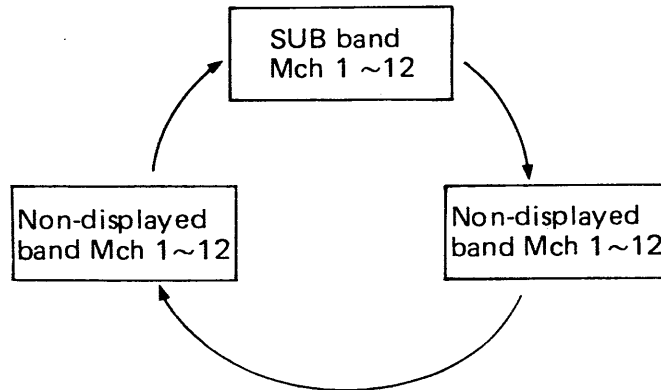

Repeatedly scans all memory channels 1 to 12 in all additional band and SUB bands except the MAIN band.

### ●Memory skip function

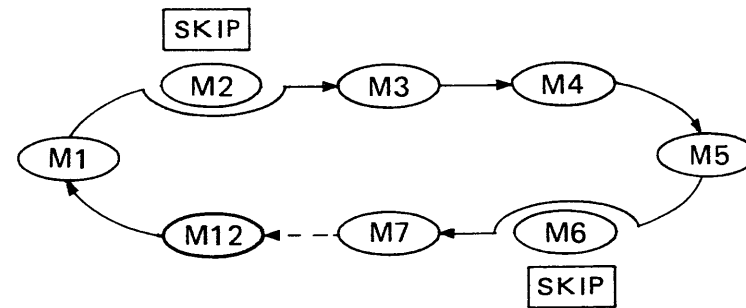

Repeatedly scans all memory channels 1 to 12 in either the MAIN or SUB band while skipping memory channels you do not wish to scan during memory scan. This is an additional function of the memory scan as above.

## 14 OPERATING SCANS

### ■ Programmed scan

- 1) Set the desired operating band to the MAIN band display.
  - See p. 28 for selecting the operating band.
- 2) Push [V/M] to select VFO mode.
  - "M" disappears.
- 3) Program the scan edge frequencies into memory channels 11 and 12. See p. 42 for memory writing procedures.
- 4) Push [SQUELCH] to close the squelch.
  - The green [T/R] indicator disappears.
- 5) Push and hold [UP] or [DN] on the microphone for approx. 1 second to start the scan. Then, release the switch.
  - [UP]: upwards scan      [DN]: downwards scan
  - The decimal point flashes while scanning.
- 6) When receiving a signal, the scan pauses for approx. 15 seconds on the frequency.
  - When the signal disappears, the scan resumes after approx. 2 seconds.
- 7) To cancel the scan, push [UP] or [DN] on the microphone again.
  - The main dial and some other switches also cancel the scan.

### ● SUB band programmed scan

Programmed scan can also be activated in SUB band.

- 1) Push [SUB] to access the SUB band.
  - "SUB" appears.
- 2) Set the desired operating band in the SUB band display.
- 3) Follow steps 2 ~ 7 at left.
- 4) When no signal is received during scanning for approx. 30 seconds, the operating band automatically returns from the SUB band to the MAIN band.
  - "SUB" disappears.
- 5) To cancel the scan:
  - When "SUB" appears, push [UP] or [DN] on the microphone.
  - When "SUB" disappears, push [SUB] to access the SUB band, then push [UP] or [DN] on the microphone.



## ■ Memory scan

- 1) Set the desired operating band to the MAIN band display.
  - See p. 28 for selecting the operating band.
- 2) Program the desired frequency into memory channels.
  - See p. 42 for memory writing procedures.
- 3) Push [V/M] to select MEMORY mode.
  - "M" appears.
- 4) Push [SQUELCH] to close the squelch.
  - The green [T/R] indicator disappears.
- 5) Push and hold [UP] or [DN] on the microphone for approx. 1 second to start the scan. Then, release the switch.
  - [UP]: upwards scan      [DN]: downwards scan
  - The decimal point and "M" flash while scanning.
- 6) When receiving a signal, the scan pauses for approx. 15 seconds on the frequency.
  - When the signal disappears, the scan resumes after approx. 2 seconds.
- 7) To cancel the scan, push [UP] or [DN] on the microphone.
  - The main dial and some other switches also cancel the scan.

## ● SUB band memory scan

Memory scan can also be activated in SUB band.

- 1) Push [SUB] to access the SUB band.
  - "SUB" appears.
- 2) Set the desired operating band in the SUB band display.
- 3) Follow steps 2 ~ 7 at left.
- 4) When no signal is received during scanning for approx. 30 seconds, the operating band automatically returns from the SUB band to the MAIN band.
  - "SUB" disappears.
- 5) To cancel the scan:
  - When "SUB" still appears, push [UP] or [DN] on the microphone.
  - When "SUB" disappears, push [SUB] to access the SUB band, then push [UP] or [DN] on the microphone.

## 14 OPERATING SCANS

### Multi-band memory scan

- 1) Turn the multi-band memory scan function ON in SET mode.
  - See at right for turning the function ON and OFF.
- 2) Push [SUB] to select the SUB band.
  - "SUB" appears.
- 3) Push [V/M] to select the MEMORY mode.
  - "M" appears.
- 4) Push [SQUELCH] to close the squelch.
  - The green [T/R] indicator disappears.
- 5) Push and hold [UP] or [DN] on the microphone for approx. 1 second to start the scan. Then, release the switch.
  - [UP]: upwards scan      [DN]: downwards scan
  - The decimal point, "BAND" and "M" flash while scanning.
- 6) When receiving a signal, the scan pauses for approx. 15 seconds on the frequency.
  - When the signal disappears, the scan resumes after approx. 2 seconds.
- 7) To cancel the scan:
  - When "SUB" still appears, push [UP] or [DN] on the microphone.
  - When "SUB" disappears, push [SUB] to access the SUB band, then push [UP] or [DN] on the microphone.

#### USING SET MODE

##### • Turning ON and OFF the Multi-band memory scan

- 1) Push [SUB] to access SUB band.

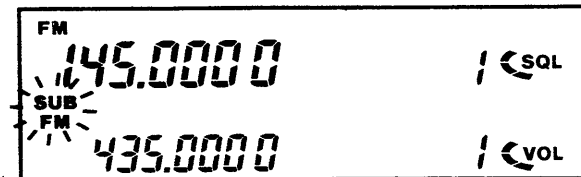

- 2) Push [SET] several times until "BAND" flashes and "on" or "off" appears.

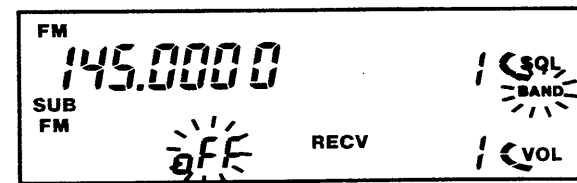

- 3) Rotate the main dial to turn ON or OFF the function.

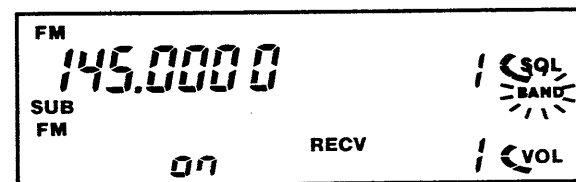

Multi-band  
memory scan:  
ON

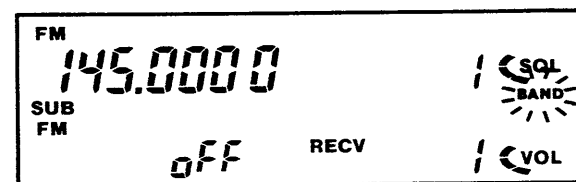

Multi-band  
memory scan:  
OFF

- 4) To set the condition and return to the previous display, push [CHECK].

## Memory skip function

### ● Programming skip channels

- 1) Push [V/M] to select MEMORY mode.
  - "M" appears.

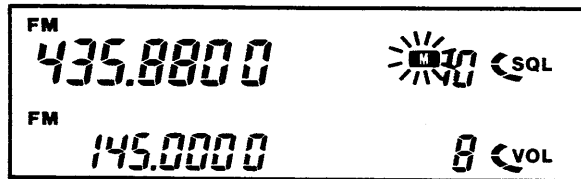

- 2) Select a desired memory channel as a skip channel with the main dial or [UP] or [DN] on the microphone.
- 3) Push [MHz] to program the displayed memory channel as the skip channel.
  - "SKIP" appears.

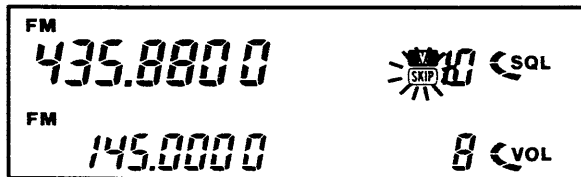

- 4) To cancel the skip channel, push the [MHz] switch again.
  - "SKIP" disappears.

### ● Scanning with the skip function

To start the scan after setting skip channels, follow procedures below:

- 1) Push [V/M] to select MEMORY mode.
  - "M" appears.
- 2) Push [UP] or [DN] on the microphone to start the scan.
- 3) To stop the scan, push [UP] or [DN] on the microphone again.
- 4) To select a SUB band memory channel, push [SUB] then follow steps from 1 above.

## ■ Operating the RIT/VXO functions

### ● Outlines

To compensate for off frequency of the transmitting station, the IC-901A/E is equipped with RIT and VXO functions.

The functions operate only in the 1200 MHz band in FM mode and 144 MHz band in SSB/CW mode.

FUNCTION	DESCRIPTION
RIT (OPTIONAL)	<p><b>Function:</b> Shifts only the receive frequency* without shifting the transmit frequency.</p> <p><b>Using RIT:</b> Use this function for tuning a frequency of the transmitting station when working with the station.</p>
VXO (OPTIONAL)	<p><b>Function:</b> Finely shifts both the receive and transmit frequencies* simultaneously.</p> <p><b>Using VXO:</b> Use this function when finely tuning both the transmit and receive operating frequencies simultaneously instead of using the main dial.</p>

\* Shift frequency and the frequency increment steps differ depending on the operating band. See p. 50.

### ● Operation

Both RIT and VXO functions cannot be used simultaneously. The VXO function activates only in the MAIN band.

- 1) Select the desired function for RIT or VXO using SET mode. See pgs. 52 ~ 54 for SET mode information.
- 2) Push [TS] to turn ON a function.
  - "RIT" appears when RIT is pre-selected.
  - "VXO" appears when VOX is pre-selected.

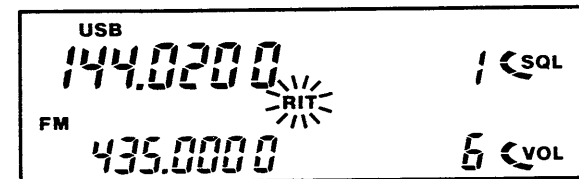

RIT activates.

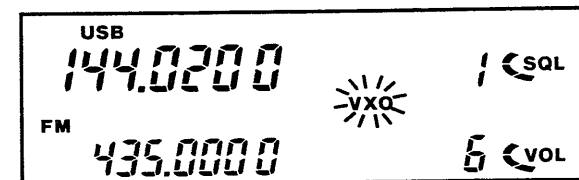

VXO activates.

- 3) Rotate the main dial to shift the operating frequency.
  - The relative shift frequency appears as a number.
  - The number will disappear 2 seconds after the shift frequency is set.
  - The speaker emits beep tones to indicate that the shift frequency is at zero, maximum or minimum.
- 4) Push [TS] to turn OFF the function after finishing operation.

**Example**

Following are shift frequency ranges and frequency increments for 144 MHz SSB/CW and 1200 MHz FM modes.

FUNCTION	144 MHz SSB/CW MODE	1200 MHz FM MODE
RIT/VXO FUNCTIONS	<ul style="list-style-type: none"> <li>•Shift frequency range: ±1 kHz</li> <li>•Frequency increment: ±63 steps</li> </ul>	<ul style="list-style-type: none"> <li>•Shift frequency range: ±6 kHz</li> <li>•Frequency increment: ±7 steps</li> </ul>

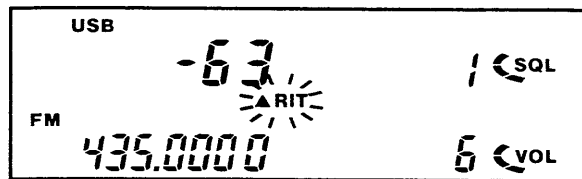

144 MHz (SSB/CW)  
RIT activates.  
Shift freq.: -1 kHz

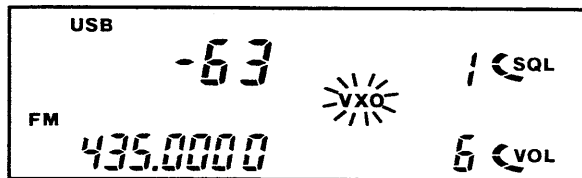

144 MHz (SSB/CW)  
VXO activates.  
Shif freq.: -1 kHz

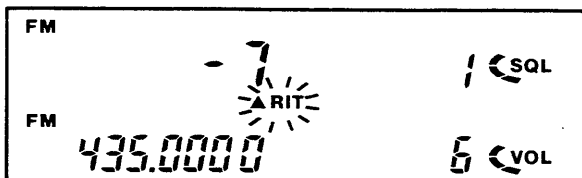

1200 MHz (FM)  
RIT activates.  
Shift freq.: -6 kHz

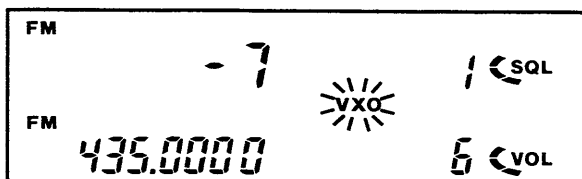

1200 MHz (FM)  
VXO activates.  
Shift freq.: -6 kHz

USING SET MODE

**•Turning on and off the RIT/VXO function**

The functions operate only in the 1200 MHz band in FM mode and the 144 MHz band in SSB/CW mode.

- 1) Push [SET] several times until "RIT" flashes.
- 2) Rotate the main dial to select the desired function.
- 3) Push [V/M] twice to return to the previous display.

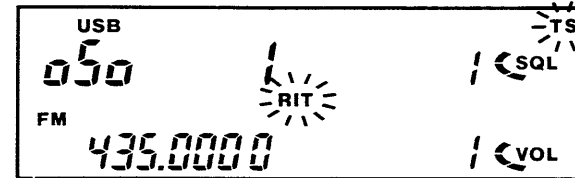

Main dial rotation changes functions.

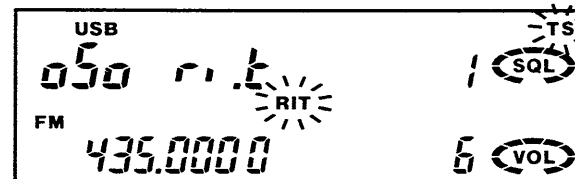

RIT is selected.

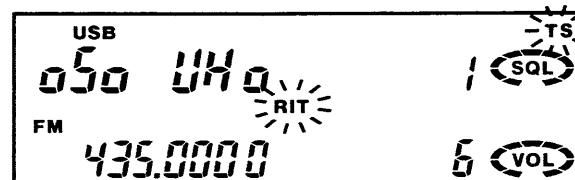

VXO is selected.

## 15 SPECIAL FUNCTIONS

### ■ Changing backlight intensity

The intensity of the function display backlight is selectable in 2 levels. The setting can be changed in SET mode as follows:

- 1) Push [SET] several times until "d-oFF" or "d-on" appears.
- 2) Rotate the main dial for the desired lighting intensity.
  - "d-oFF" : Lighter
  - "d-on" : Darker
- 3) Push [V/M] to set the intensity and exit SET mode.

USING SET MODE

The diagram shows two states of the display. In the top state, the display shows "d-on" in the top left, "6 SQL" in the top right, "FM 145.0000" in the bottom left, and "8 VOL" in the bottom right. To the right of the display, it says "Dimmer ON: Darker". In the bottom state, the display shows "d-off" in the top left, "6 SQL" in the top right, "FM 145.0000" in the bottom left, and "8 VOL" in the bottom right. To the right of the display, it says "Dimmer OFF: Lighter".

### ■ Turning on/off the beep tone

The speaker emits a beep tone each time a switch is pushed. This beep tone can be turned ON and OFF in SET mode as follows:

- 1) Push [SET] several times until "b-on" or "b-oFF" appears.
- 2) Rotate the main dial to select beep ON and OFF.
- 3) Push [V/M] to select the condition and exit SET mode.

USING SET MODE

The diagram shows two states of the display. In the top state, the display shows "b-on" in the top left, "6 SQL" in the top right, "FM 145.0000" in the bottom left, and "8 VOL" in the bottom right. To the right of the display, it says "Beep ON". In the bottom state, the display shows "b-off" in the top left, "6 SQL" in the top right, "FM 145.0000" in the bottom left, and "8 VOL" in the bottom right. To the right of the display, it says "Beep OFF".

# SET mode in FM mode

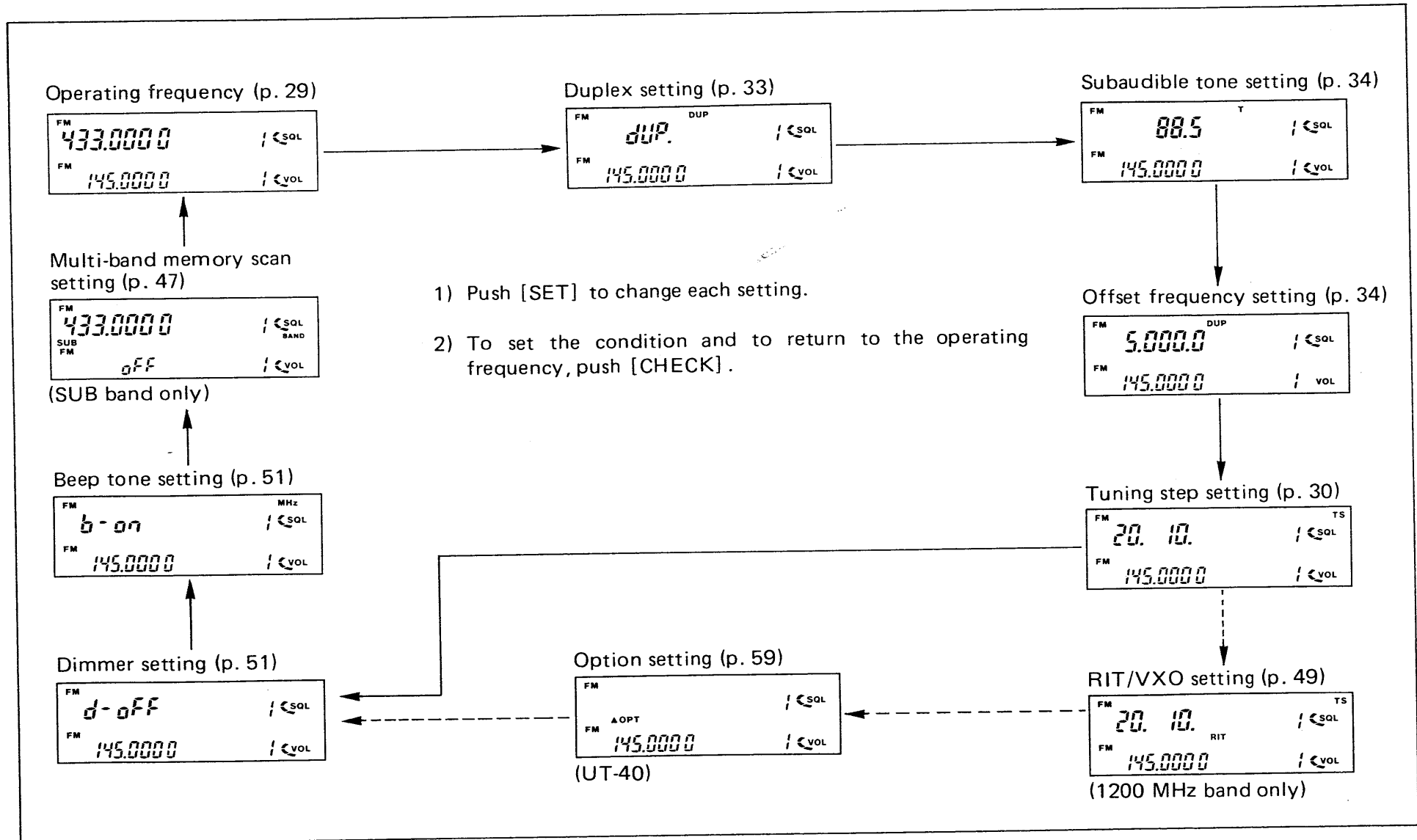

## ■ SET mode outline

Seldom-used functions or contents such as dimmer on/off, beep on/off, offset frequency, etc., can be set in SET mode. SET mode displays are different depending on the operating mode for FM mode, SSB/CW mode (optional) and RECEIVER mode (optional).

### ● SET mode contents in FM mode

- Duplex condition
- Subaudible tone frequency
- Offset frequency
- Tuning step increment
- RIT/VXO (only 1200 MHz band)
- Optional tone unit (with an UT-40 installed)
- Dimmer on/off
- Beep on/off
- Multi-band memory scan on/off (SUB band)

### ● SET mode contents in SSB/CW mode

- AGC slow/fast
- Tuning step increment
- RIT/VXO
- Dimmer on/off
- Beep on/off
- Multi-band memory scan on/off (SUB band)

### ● SET mode contents in RECEIVER mode

- Receive band selection
- Volume balance for FM stereo signals
- Dimmer on/off
- Beep on/off
- Multi-band memory scan on/off (SUB band)

## ■ Accessing SET mode

- 1) Select the desired operating band or mode.
  - See p. 28 for selecting the operating band.
- 2) Push [SET] to access SET mode.
  - The function display shows a SET mode display.
- 3) Push [SET] until the desired display and contents you want to change appear.
  - See pgs. 53 and 54 for the SET mode construction chart.
- 4) Set the desired contents with the main dial.
- 5) To return to the previous display:
  - In FM mode, push the [CHECK] switch.
  - In SSB or CW mode, push the [V/M] switch twice.
  - In Call channel mode, push the [CALL] switch twice.
  - In RECEIVER mode, push the [CHECK] switch.

**NOTE:** SET mode can be accessed from either or MEMORY mode. However, changed contents using SET mode are erased when SET mode is accessed from the MEMORY mode then the VFO mode is selected through the MEMORY mode.



## ■ SET mode in SSB/CW mode

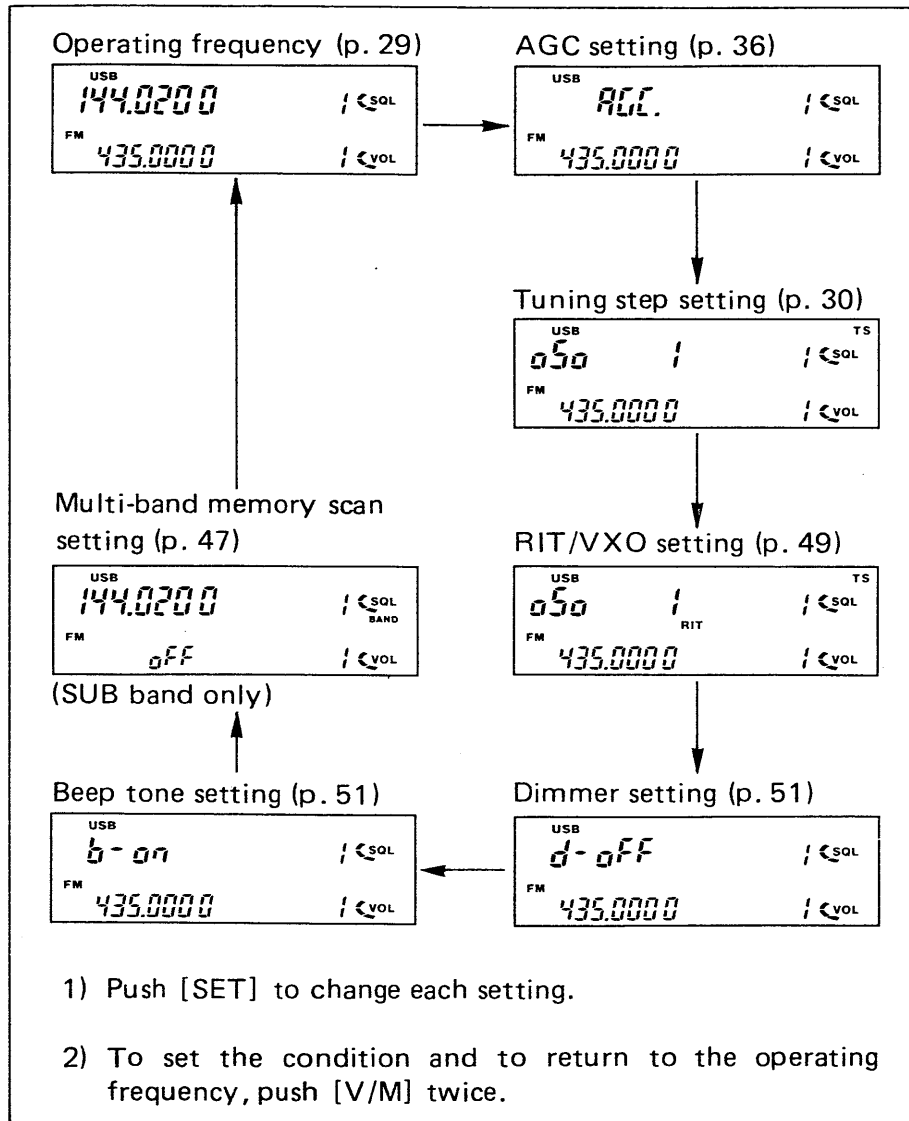

## ■ SET mode in RECEIVER mode

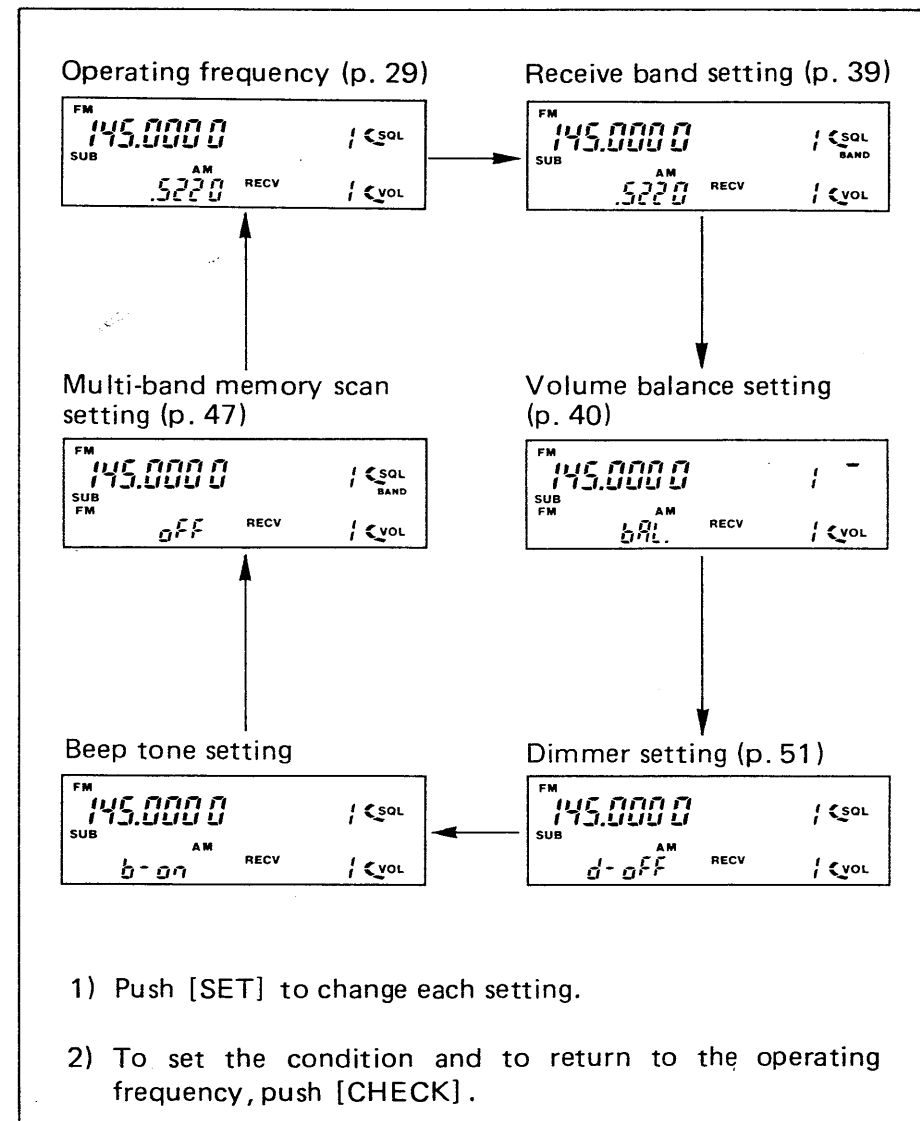

## ■ Installing UT-40 and UT-48

**CAUTION:** Turn OFF power and DISCONNECT the power cable before removing the cover from the transceiver.

### ●Cover removal

- 1) Remove 6 screws on the rear panel and remove the fan cover from the transceiver. (Fig. 1)
- 2) Remove 3 screws and remove the bottom cover as shown in the figure. (Fig. 2)

### ●UT-40 installation

- 1) Open the bottom cover to follow instructions in the cover removal.
- 2) Connect the UT-40 to the 10-pin plug. (Fig. 3)
  - When installing two UT-40s, disconnect the built-in tone encoder, then replace with the UT-40.
- 3) Remove the protective paper from the back of the UT-40 to expose the adhesive strip.
- 4) Install the unit in the location as shown in the figure. (Fig. 4)
- 5) Replace the bottom cover and the fan cover.

### ●UT-48 installation

- 1) Open the bottom cover to follow instructions in the cover removal.
- 2) Connect the UT-48 to the 14-pin plug. (Fig. 5)
- 3) Temporarily remove the built-in tone encoder from the transceiver.
  - When the UT-40 is installed, also temporarily remove it.
- 4) Remove the protective paper from the back of the UT-48 to expose the adhesive strip.
- 5) Install the unit in the place where the built-in tone encoder was installed as shown in the figure. (Fig. 4)
- 6) Install the built-in tone encoder or UT-40 onto the installed UT-48. (Fig. 6)
- 7) Replace the bottom cover and the fan cover.

## ●Cover removal

- 1) Remove 6 screws.
- 2) Remove the fan cover.

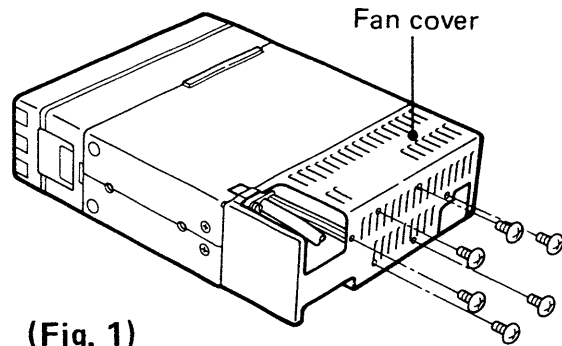

(Fig. 1)

- 1) Remove 3 screws.
- 2) Remove the bottom cover.

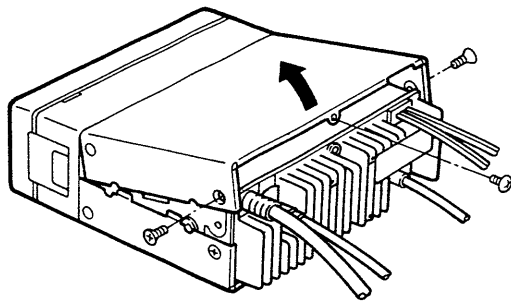

(Fig. 2) Some versions do not have a fan installed.

## ●UT-40 installation

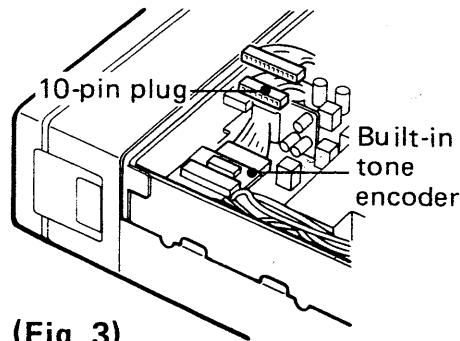

(Fig. 3)

- 1) Connect the UT-40 to the 10-pin plug.
- 2) Install the unit.

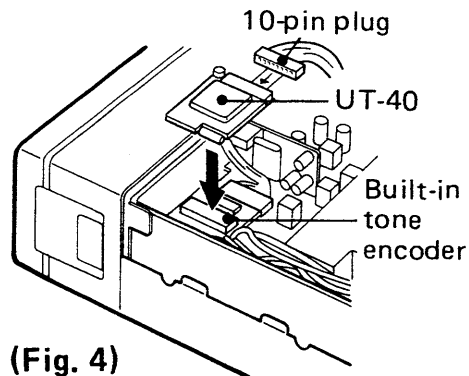

(Fig. 4)

## ●UT-48 installation

- 1) Connect the UT-48 to the 14-pin plug.
- 2) Install the unit.

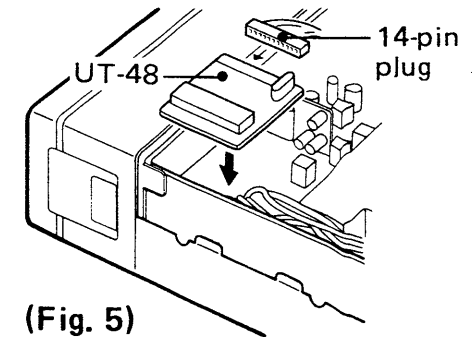

(Fig. 5)

When installing 2 UT-40s and the UT-48, install units as in the following diagram.

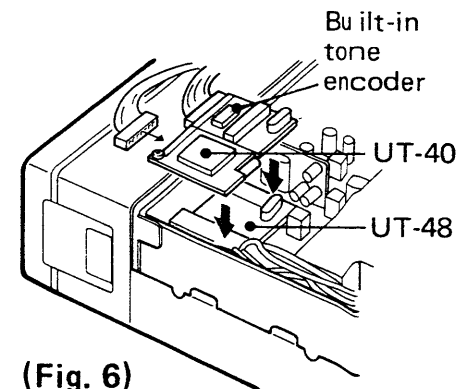

(Fig. 6)

# 17 SELECTIVE CALLING (OPTIONAL)

## ■ Selective calling system

Each function shown below is useful to call a specific station or for standby from a specific station. To operate these functions, an optional UT-40 or UT-48 is necessary.

	SYSTEM	DESCRIPTION	OPTION
SELECTIVE CALLING	POCKET BEEP	This function alerts you with approx. 30 sec. beep tones and the "(((·)))" indicator flashing a signal with the same subaudible tone as pre-programmed is received.	UT-40
	PAGER	This function displays the received ID code with beeps. ID codes can be independently programmed in each station. You can therefore choose to call a personal station or group stations.	UT-48
COMMUNICATION	STONE SQUELCH	When a signal with the same subaudible tone as that pre-programmed is received, the squelch opens. You can silently wait for a call from your group.	UT-40
	CODE SQUELCH	When a signal with the same ID code as that pre-programmed is received, the squelch opens. Or a group call can be selected the same as the pager function..	UT-48

All functions as above do not function in SSB and CW modes. The pocket beep and pager or code squelch cannot be used at the same time.

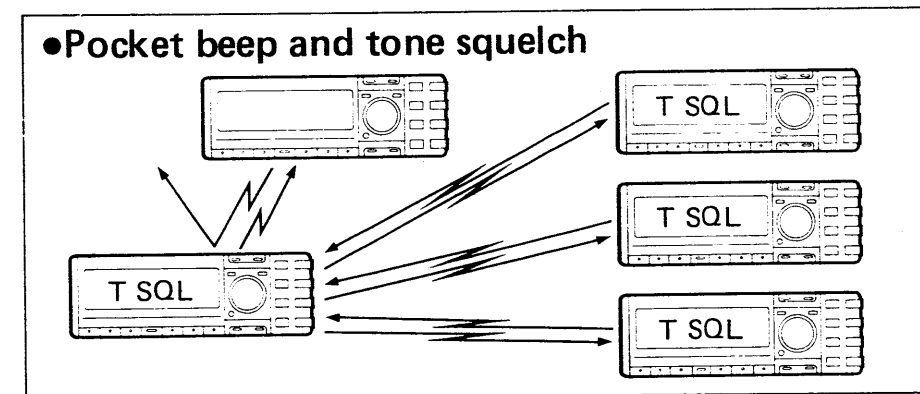
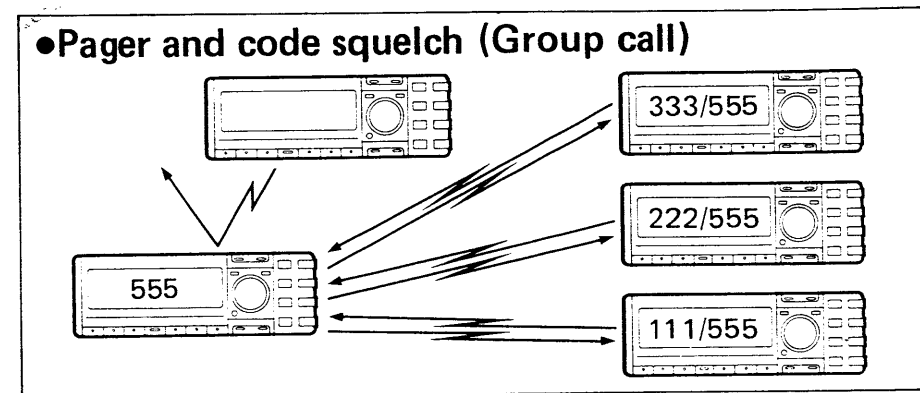
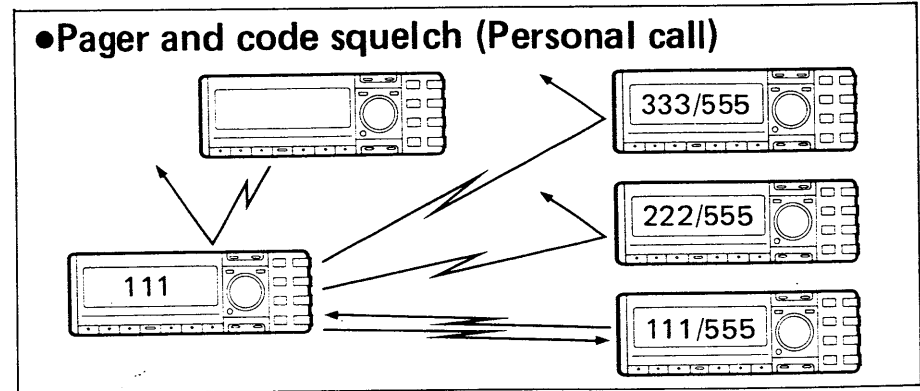

## ■ Operating pocket beep and tone squelch

An optional UT-40 TONE SQUELCH UNIT is necessary for this operation.

- 1) Set the desired operating band and frequency in the MAIN band display.
  - The function does not operate in SSB/CW mode.
- 2) Set a tone frequency using SET mode. The frequency must be the same on both communicating stations.
  - See p. 34 for frequency setting instructions.
- 3) Select the optional unit connection to the MAIN or SUB band using SET mode.
  - See p. 59 for selection instructions.
- 4) Push [T/T.SQL] to select the function as shown below.

### • Normal display

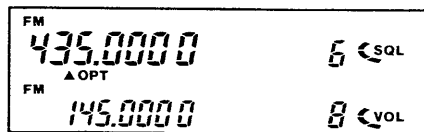

### • Tone encoder display



### • Tone squelch display

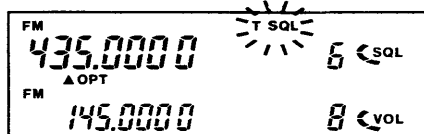

### • Pocket beep display

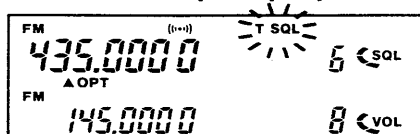

### • When receiving a selective call (Pocket beep only)

When a call including the correct tone is received, the transceiver emits beeps for 30 sec. and flashes "(((•)))".

- In this time, push [T/T.SQL] or the PTT switch to stop beeps and flashing. The transceiver automatically selects the tone squelch function.
- 5) Operate the transceiver in the normal way (push PTT to transmit and release to receive).
    - To monitor these signals, push [CHECK].
    - Signals without a tone or with an incorrect tone cannot be received.
  - 6) To cancel the function, push [T/T.SQL] until "T SQL" disappears.
    - The function should be turned OFF for both stations.

**CONVENIENT:** Tone squelch with a tone frequency can be programmed in a memory channel. Therefore, SET mode is not necessary once a memory is programmed.

# 17 SELECTIVE CALLING (OPTIONAL)

## USING SET MODE

### ● Selecting the UT-40 connection

When the optional UT-40 TONE SQUELCH UNIT is installed in the transceiver, you can select connection to either the MAIN and SUB band using SET mode.

The UT-40 functions only in FM mode.

- 1) Push [SET] several times until "OPT" flashes.
- 2) Rotate the main dial to select the UT-40 connection.
  - To connect the MAIN band : "▲" appears.
  - To connect the SUB band : "▼" appears.
- 3) Push [CHECK] to set the selection and to return to the previous display.



The display above shows that the UT-40 is connected to the MAIN band.

## ■ Programming a code

Pager and code squelch require codes to acknowledge the specified station using the optional UT-48.

CODE CHANNEL	DESCRIPTION	<b>SKIP</b> (Inhibit or accept)
0	Program your ID code.	"Accept" only.
1 ~ 5	Program other station's ID codes or the group code.	Program "SKIP" (inhibit) for other station's ID code. Program "non-SKIP" (accept) for the group code.
P	Space for the received code programming space.	"inhibit" only

- 1) Set the desired band in the MAIN band display.
  - The function does not operate in SSB/CW mode.
- 2) Push [MODE] to select the pager function.
  - "P" appears instead of the memory channel number.
- 3) Push [SET] to enter to the code programming condition as shown below.

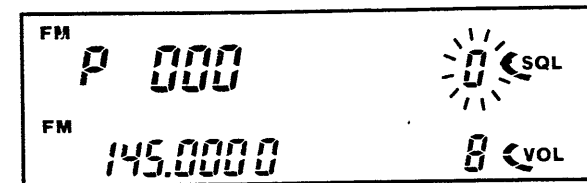

- 4) Rotate the tuning control to select the desired code channel.
  - Channel P cannot be programmed.
- 5) Push [MODE] for the programming digit to flash.
- 6) Rotate the tuning control to set the code number.
- 7) Repeat steps 5 and 6 to program all 3 digits.

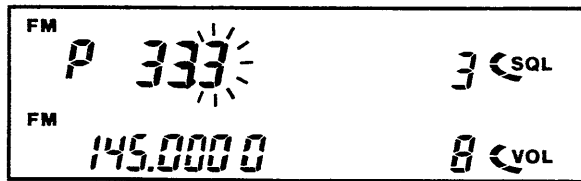

- 8) Push [MODE] until the channel number flashes.
- 9) Push [MHz] to indicate or erase "SKIP."

Appears for inhibit and disappears for accept.

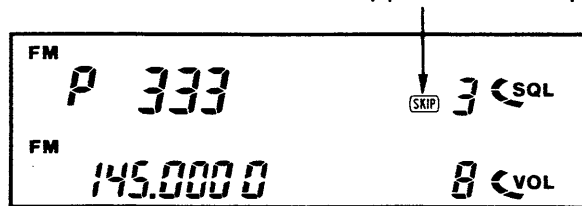

- 10) Push [SET] to return to the previous display or repeat from step 4 to program another channel.

## ■ Operating code squelch

- 1) Set the desired operating band and frequency in the MAIN band display.
  - The function does not operate in SSB/CW mode.
- 2) Push [MODE] 2 times until "c" appears instead of the memory channel number.
- 3) Select the desired code memory channel.
  - Personal communication : ID code channel
  - Group communication : Group code channel
  - See p. 62 for selecting a code memory channel.
- 4) Operate the transceiver in the normal way (push PTT to transmit and release to receive).
  - A 3-digit code is transmitted at the beginning of the signal.
  - Signals without a code or with an incorrect code cannot be received.
  - To monitor these signals, push [CHECK].
- 5) To cancel the function, push [MODE] until "c" disappears and a memory channel number appears.
  - The function should be turned OFF for both stations.

# 17 SELECTIVE CALLING (OPTIONAL)

## ■ Operating pager code squelch

The following steps in the charts should be read in sequence. Step 1 in the TRANSMITTER SIDE STATION column, for example, corresponds to step 1 in the RECEIVER SIDE STATION column.

### PRE-OPERATION:

- 1) Determine ID codes on each station and the group code.
- 2) Program ID codes and the group code in each transceiver. See "Code programming" on p. 60.

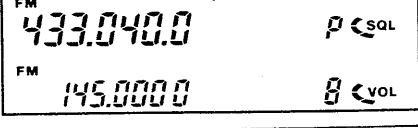
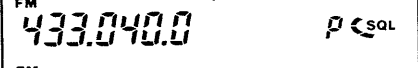
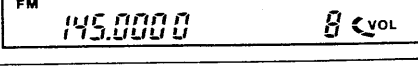
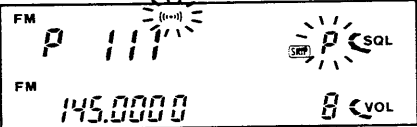
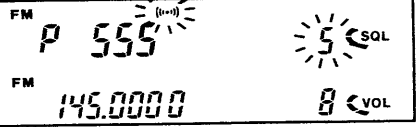
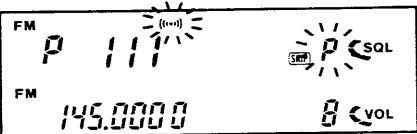
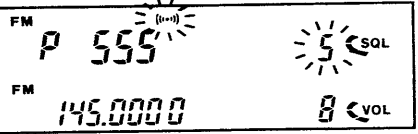
TRANSMITTER SIDE STATION	RECEIVER SIDE STATION
1) Set the desired operating band and frequency in the MAIN band display. • The function does not operate in SSB/CW mode.	1) Set the desired operating band and frequency in the MAIN band display. • The function does not operate in SSB/CW mode.
2) Push [MODE] until "P" appears instead of the memory channel number. <div style="display: flex; justify-content: space-around; align-items: center;">   </div>	2) Push [MODE] until "P" appears instead of the memory channel number. <div style="display: flex; justify-content: space-around; align-items: center;">   </div>
3) Select the desired code memory channel. See at right (p. 62) below for selection. <div style="display: flex; justify-content: space-around; margin-top: 10px;"> <div style="text-align: center;"> <p>Personal call</p>  </div> <div style="text-align: center;"> <p>Group call</p>  </div> </div> <p>If the ID code of the receiver station is programmed in Channel 1 the display shows as above.</p> <p>If the group code is programmed in Channel 5 the display shows as above.</p>	3) When receiving a call, the display shows as follows with beeps: <div style="display: flex; justify-content: space-around; margin-top: 10px;"> <div style="text-align: center;"> <p>When receiving a call with your ID code.</p>  </div> <div style="text-align: center;"> <p>When receiving a call with the group code.</p>  </div> </div> <p>If the ID code of the transmitter station is "111," the displays shows as above.</p> <p>If the group code is programmed in Channel 5 the display shows as above.</p>
4) Push [SET] to return to the normal display. 5) Push the PTT switch to transmit the selected code. • The speaker also emits the selected code.	



TRANSMITTER SIDE STATION	RECEIVER SIDE STATION
<p>6) Wait for an answer back from the contacting station.</p>	<p>4) Push the PTT switch to transmit the answer back call.</p> <div style="border: 1px solid black; padding: 5px; width: fit-content; margin: 10px auto;"> <div style="display: flex; justify-content: space-between; align-items: center;"> <span style="font-size: small;">FM</span> <span style="font-size: large; font-weight: bold;">433.0400</span> <span style="font-size: small;">P SQL</span> </div> <div style="display: flex; justify-content: space-between; align-items: center;"> <span style="font-size: small;">FM</span> <span style="font-size: large; font-weight: bold;">145.0000</span> <span style="font-size: small;">8 VOL</span> </div> </div>
<p>7) When receiving an answer back, the function display shows the Channel P or the group code channel.</p>	<p>5) Push [MODE] as soon as transmit is finished to advance to code squelch.  <ul style="list-style-type: none"> <li>• To also turn OFF code squelch, push [MODE] again.</li> </ul> </p>
<p>8) Push the PTT switch to return to the previous display.  <ul style="list-style-type: none"> <li>• The answer back is transmitted.</li> </ul> <p>9) Push [MODE] as soon as transmit is finished to advance to code squelch.  <ul style="list-style-type: none"> <li>• To also turn OFF code squelch, push [MODE] again.</li> </ul> </p> </p>	
<p>10) Operate the transceiver with the code squelch. See p. 59 for details.</p>	<p>6) Operate the transceiver with the code squelch. See p. 59 for details.</p>

CODE CHANNEL SELECTION:	
<p>1) Be sure the pager function is turned ON.</p>	<p>3) Rotate the tuning control to select the channel.</p>
<div style="border: 1px solid black; padding: 5px; width: fit-content; margin: 10px auto;"> <div style="display: flex; justify-content: space-between; align-items: center;"> <span style="font-size: small;">FM</span> <span style="font-size: large; font-weight: bold;">433.0400</span> <span style="font-size: small;">P SQL</span> </div> <div style="display: flex; justify-content: space-between; align-items: center;"> <span style="font-size: small;">FM</span> <span style="font-size: large; font-weight: bold;">145.0000</span> <span style="font-size: small;">8 VOL</span> </div> </div>	<div style="border: 1px solid black; padding: 5px; width: fit-content; margin: 10px auto;"> <div style="display: flex; justify-content: space-between; align-items: center;"> <span style="font-size: small;">FM</span> <span style="font-size: large; font-weight: bold;">P 222</span> <span style="font-size: small;">1 SQL</span> </div> <div style="display: flex; justify-content: space-between; align-items: center;"> <span style="font-size: small;">FM</span> <span style="font-size: large; font-weight: bold;">145.0000</span> <span style="font-size: small;">8 VOL</span> </div> </div>
<p>2) Push [SET] to advance the display for code selection.</p>	<p>4) Push [SET] again to return to the operating frequency.</p>
<div style="border: 1px solid black; padding: 5px; width: fit-content; margin: 10px auto;"> <div style="display: flex; justify-content: space-between; align-items: center;"> <span style="font-size: small;">FM</span> <span style="font-size: large; font-weight: bold;">P 333</span> <span style="font-size: small;">3 SQL</span> </div> <div style="display: flex; justify-content: space-between; align-items: center;"> <span style="font-size: small;">FM</span> <span style="font-size: large; font-weight: bold;">145.0000</span> <span style="font-size: small;">8 VOL</span> </div> </div>	<div style="border: 1px solid black; padding: 5px; width: fit-content; margin: 10px auto;"> <div style="display: flex; justify-content: space-between; align-items: center;"> <span style="font-size: small;">FM</span> <span style="font-size: large; font-weight: bold;">433.0400</span> <span style="font-size: small;">P SQL</span> </div> <div style="display: flex; justify-content: space-between; align-items: center;"> <span style="font-size: small;">FM</span> <span style="font-size: large; font-weight: bold;">145.0000</span> <span style="font-size: small;">8 VOL</span> </div> </div>

## ■ Troubleshooting

	PROBLEM	POSSIBLE CAUSE	SOLUTION	REF.
POWER SUPPLY	<ul style="list-style-type: none"> <li>Power does not come on when [PWR] is pushed.</li> </ul>	<ul style="list-style-type: none"> <li>Power cable is improperly connected.</li> <li>Fuse is blown. (Fuses are installed in the DC power cable.)</li> <li>Polarity of power cable connection is reversed.</li> <li>Remote control cable is not connected properly.</li> </ul>	<ul style="list-style-type: none"> <li>Reconnect the power cable securely.</li> <li>Check for the cause, then replace the fuse with a spare one. DC power cable: 20 A</li> <li>Connect the cable properly. red → positive black → negative</li> <li>Check the cable connections between the remote controller and main body.</li> </ul>	<p>p. 19</p> <p>pgs. 19, 65</p> <p>p. 19</p> <p>p. 14</p>
RECEIVE	<ul style="list-style-type: none"> <li>No sound comes from the speaker.</li> </ul>	<ul style="list-style-type: none"> <li>Volume level is too low.</li> <li>The squelch is closed.</li> <li>An external speaker or headphones are in use.</li> <li>The optional tone squelch is turned ON when the UT-40 is installed.</li> </ul>	<ul style="list-style-type: none"> <li>Push [VOLUME] to increase the volume level.</li> <li>Push [SQUELCH] to open the squelch.</li> <li>Check the external speaker or headphones plug connection.</li> <li>Push [T/T•SQL] to turn OFF the function.</li> </ul>	<p>p. 5</p> <p>p. 5</p> <p>pgs. 22~23</p> <p>pgs. 57~58</p>
	<ul style="list-style-type: none"> <li>Sensitivity is low.</li> </ul>	<ul style="list-style-type: none"> <li>The antenna feedline is cut or shorted.</li> <li>Wrong antenna is connected to the antenna connector.</li> </ul>	<ul style="list-style-type: none"> <li>Check the feedline and correct any improper conditions.</li> <li>Proper band antenna should be connected: SO-239 → 144 MHz antenna Type-N → 430(440) MHz antenna</li> </ul>	<p>p. 21</p> <p>p. 7</p>
TRANSMIT	<ul style="list-style-type: none"> <li>Repeater cannot be accessed.</li> </ul>	<ul style="list-style-type: none"> <li>A wrong offset frequency is set.</li> <li>The repeater requires a subaudible tone.</li> </ul>	<ul style="list-style-type: none"> <li>Set the correct offset frequency using SET mode.</li> <li>Set the subaudible tone using SET mode.</li> </ul>	<p>p. 34</p> <p>p. 34</p>
	<ul style="list-style-type: none"> <li>Output power is low.</li> <li>No contact possible with another station.</li> </ul>	<ul style="list-style-type: none"> <li>Output power is set at low.</li> <li>The transceiver is set to duplex.</li> </ul>	<ul style="list-style-type: none"> <li>Push [H/L] to set the power at high.</li> <li>Set the transceiver to simplex using SET mode.</li> </ul>	<p>pgs. 32, 37</p> <p>p. 33</p>

	PROBLEM	POSSIBLE CAUSE	SOLUTION	REF.
DISPLAY	<ul style="list-style-type: none"> <li>The displayed frequency does not change properly.</li> </ul>	<ul style="list-style-type: none"> <li>The dial lock function is activated.</li> <li>The internal CPU has malfunctioned.</li> <li>Call channel is selected.</li> </ul>	<ul style="list-style-type: none"> <li>Push [LOCK] to turn OFF the dial lock function.</li> <li>Turn the power OFF. While pushing [CHECK] and [MW], turn ON power again.</li> <li>Push [CALL] to return to the previous display condition.</li> </ul>	p. 29
				p. 65
SCAN	<ul style="list-style-type: none"> <li>No scans operate.</li> </ul>	<ul style="list-style-type: none"> <li>Squelch is open.</li> <li>The [UP/DN] switch on the microphone is set in OFF position.</li> <li>The dial lock function is activated.</li> <li>Call channel is selected.</li> </ul>	<ul style="list-style-type: none"> <li>Push [SQUELCH] to close the squelch.</li> <li>Set [UP/DN] to ON position.</li> <li>Push [LOCK] to turn OFF the function.</li> <li>Push [CALL] to return to the previous display condition.</li> </ul>	pgs. 45 ~ 48 p. 8
				p. 29
MALFUNCTION	<ul style="list-style-type: none"> <li>All programmed memories have been erased.</li> </ul>	<ul style="list-style-type: none"> <li>The built-in backup battery is empty.</li> </ul>	<ul style="list-style-type: none"> <li>Replace the backup battery.</li> </ul>	p. 65
	<ul style="list-style-type: none"> <li>The displayed frequency does not change properly.</li> </ul>	<ul style="list-style-type: none"> <li>The dial lock function is activated.</li> <li>The internal CPU has malfunctioned.</li> <li>Call channel is selected.</li> <li>Tuning step is not set in the desired step.</li> </ul>	<ul style="list-style-type: none"> <li>Push [LOCK] to turn OFF the dial lock function.</li> <li>Reset the CPU.                             <ul style="list-style-type: none"> <li>Turn power OFF. While pushing [CHECK] and [MW], turn ON power again.</li> </ul> </li> <li>Push [CALL] to return to the previous display condition.</li> <li>Set a desired tuning step in SET mode.</li> </ul>	p. 29
				p. 65
				p. 43
	<ul style="list-style-type: none"> <li>Display backlight is dark.</li> </ul>	<ul style="list-style-type: none"> <li>The dimmer function is activated.</li> </ul>	<ul style="list-style-type: none"> <li>Turn OFF the function using SET mode.</li> </ul>	p. 51
<ul style="list-style-type: none"> <li>The function display occasionally displays erroneous information.</li> </ul>	<ul style="list-style-type: none"> <li>The internal CPU has malfunctioned.</li> </ul>	<ul style="list-style-type: none"> <li>Reset the CPU.                             <ul style="list-style-type: none"> <li>Turn power OFF. While pushing [CHECK] and [MW], turn ON power again.</li> </ul> </li> </ul>	p. 65	

## ■ Replacing a fuse

If the fuse blows or the transceiver stops functioning, find the source of the problem if possible, and replace the damaged fuse with a new, rated fuse. See diagrams below for replacing the fuse.

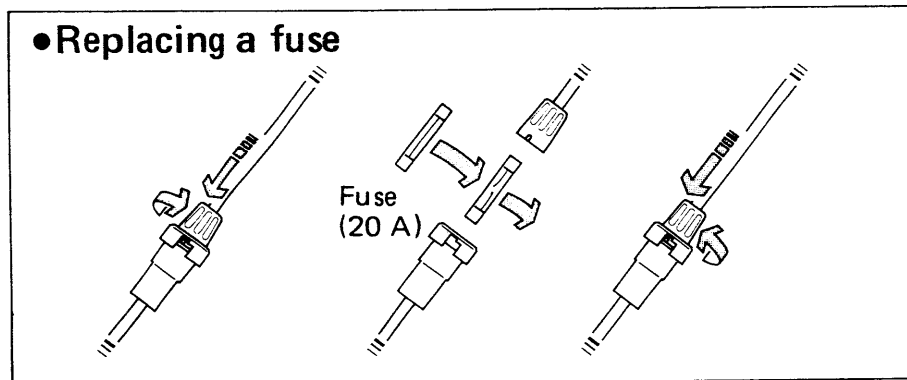

## ■ Replacing the backup battery

The transceiver has a lithium backup battery for retaining memory information.

The usual life of the backup battery is approximately five years. When the battery is exhausted, the transceiver transmits and receives normally but the transceiver cannot retain memory information.

**NOTE:** Backup battery replacement should be done by an authorized Icom Dealer or Service Center.

## ■ Resetting the CPU

If the function display occasionally displays erroneous information, the CPU should be reset before sending the transceiver to an Icom Dealer or Service Center.

**BE CAREFUL!** After resetting the CPU, all information you have programmed in SET mode and into the memory channels is erased.

- 1) Turn power OFF.
- 2) Push and hold [CHECK] and [MW], then turn power ON.
- 3) The CPU is now reset.
  - All information in the transceiver is initialized. Program the transceiver again.

## ■ Cleaning

If the transceiver becomes dusty or dirty, wipe it clean with a dry, soft cloth. Avoid the use of strong cleaning agents such as benzene or alcohol as they may damage the transceiver surfaces.

## General

- Frequency coverage :

MODEL	VERSION	VHF	UHF
IC-901A	U.S.A.	136.00 ~ 174.00 MHz* <sup>1</sup> (Rx) 140.00 ~ 150.00 MHz* <sup>1</sup> (Tx)	440.00 ~ 450.00 MHz
IC-901A	Australia	144.00 ~ 148.00 MHz	430.00 ~ 440.00 MHz
IC-901E	Europe	144.00 ~ 146.00 MHz	430.00 ~ 440.00 MHz

- Mode : F3 (FM)
- Antenna impedance : 50 Ω (unbalanced)
- Tuning step increment : See p. 29
- Power supply requirement : 13.8 V ±15%
- Number of memory channels : 12 channels + 1 call channel per each band
- Usable temperature range : -10°C ~ +60°C (+14°F ~ +140°F)
- Dimensions\*<sup>2</sup> : 150(W) x 50(H) x 191(D) mm  
59(W) x 2.0(H) x 7.5(D) in  
(projections not included)
- Weight : 1.6 kg (3.5 lb)

## Transmitter

- Output power and current drain

HI/LO	HIGH		LOW	
	BAND	POWER	CURRENT	CURRENT
VHF	50 W	12 A	5 W	5 A
UHF	35 W	11 A	5 W	5 A

- Modulation system : Variable reactance frequency modulation

Max. frequency deviation : ±5 kHz

Spurious emissions : Less than -60 dB

Microphone impedance : 600 Ω

## Receiver

- Receive system : Double-conversion superheterodyne

- Intermediate frequencies :

BAND	1ST IF	2ND IF
VHF	17.2 MHz	455 kHz
UHF	30.875 MHz	

- Sensitivity : Less than 0.18 μV for 12 dB SINAD
- Audio output power : More than 2.4 W at 10% distortion with an 8 Ω load
- Audio output impedance : 8 Ω
- Current drain : Max. audio output 1.4 A  
Squelched 850 mA

\*<sup>1</sup> Specifications apply to only 144.00 ~ 148.00 MHz.

\*<sup>2</sup> Dimensions when the transceiver is not separated.

All stated specifications are for the IC-901A/E with no option installed and are subject to change without notice or obligation.

# 20 OPTIONS

## BAND UNITS



Systematically upgrade IC-901A/E versatility with every new band unit added. See p. 4

## UX-R91A/E RECEIVER UNIT



Provides reception on the MW, VHF and UHF bands. FM stereo receiving is also made possible.

## UX-S92A/E 144 MHz SSB/CW UNIT

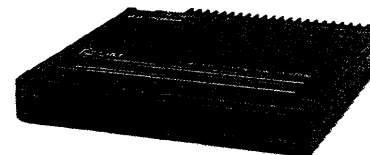

Provides operation in SSB and CW modes on the 144 MHz band. The IC-901A/E changes to a multi-mode transceiver.

## OPC-189 OPTICAL FIBER CABLE EXTENSION

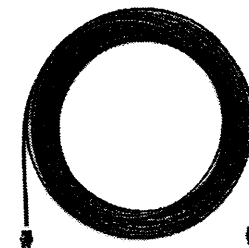

Provides longer-separation remote control operation for the transceiver.  
● Cable length : 20 m (65 ft)

## EX-766 OPTICAL FIBER CABLE INTERFACE UNIT

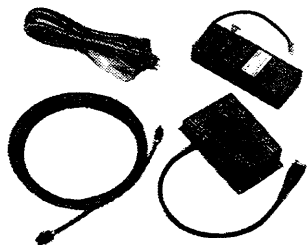

This unit is necessary when the IC-901A/E is separately installed using the optical fiber cable.

## EX-767 POWER CABLE CONNECTOR BOX

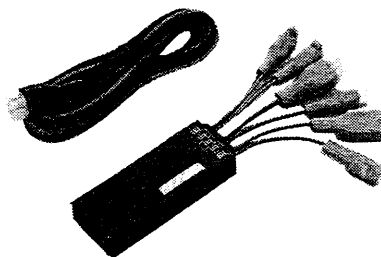

Provides DC power to optional band units. The EX-767 is needed when more than 2 band units are installed.

## UT-40 TONE SQUELCH UNIT

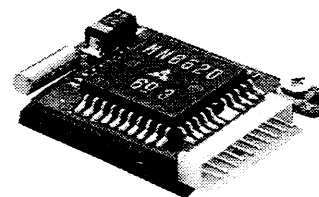

Provides pocket beep and tone squelch functions with other stations. See p. 57.

## UT-48 DTMF ENCODER/DECODER UNIT

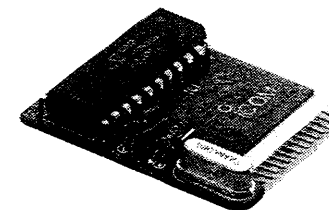

Enables you to operate the pager and code squelch functions. See p. 57.

**HS-15 FLEXIBLE MICROPHONE**

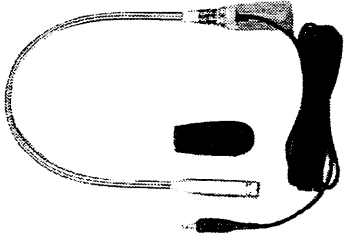

Flexible microphone for all around mobile operations. Used with the HS-15SB.

**HS-15SB PTT SWITCHBOX**

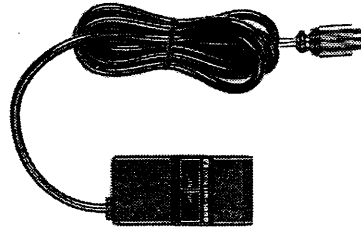

PTT switchbox for use with the HS-15. Especially convenient for mobile operation.

**SP-8 EXTERNAL SPEAKER**

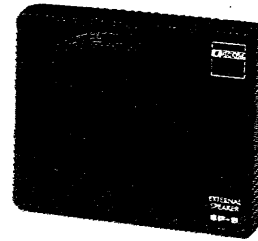

Slim-type speaker for mobile operation.

- Input impedance : 8  $\Omega$
- Max. input power : 3 W

**SP-12 EXTERNAL SPEAKER**

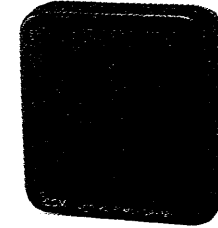

Same as the one supplied with the IC-901A/E.

- Input impedance : 8  $\Omega$
- Max. input power : 3 W

**MB-21 REMOTE CONTROLLER BRACKET**

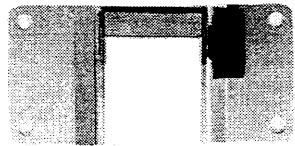

Allows mounting of the remote controller on the sun visor. Viewing angle is adjustable.

**IC-PS30 SYSTEM POWER SUPPLY**

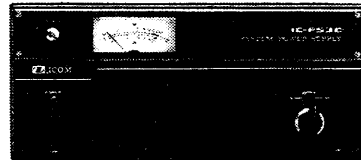

AC power supply for base station use. Provides 13.8 V DC and 25 A maximum. Comes with 3 extra output connectors.

**MB-31 BAND UNIT STACKING BRACKET**

For stacking optional band units with IC-901A/E installation. See p. 15.

**MB-32 MOUNTING BRACKET**

Used when the system is separately installed in your vehicle's trunk. See p. 18.

**Count on us!**

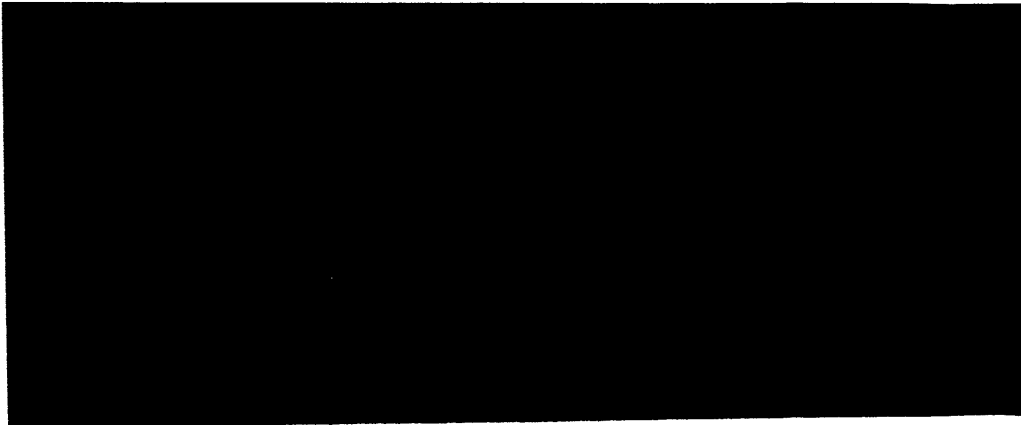

A-5078S-1EX  
Printed in Japan  
Copyright © 1989 by Icom Inc.

**Icom Inc.**  
6-9-16, Kamihigashi, Hirano-ku, Osaka 547, Japan